

# lightnet

Highlighting  
Architecture

Kumo	2-3
Serenity	4-9
Ringo Star Acoustic Oblong	10-13
Beam Me Up Soft Edge	14-27
Caleo Evolution	28-41
Matric System 25mm	42-51
Matric A7/G7/P7	52-55
Midpoint Deco	56-76
Midpoint Anti-Glare	58-78

## Kumo G1/P1 | Suspended



**DE** LED-Pendelleuchte. Direkt-indirektstrahlend. Innenliegender Leuchtenrahmen aus Aluminium. Transluzenter Textilstoff mit spezieller 3D-Falttechnik und schallabsorbierenden Eigenschaften, schwer entflammbar. Der Stoff kann beim Aufspannen verformt werden und macht jede Leuchte zu einem Unikat. Lichtstarker Indirektanteil separat steuerbar. Konverter in Leuchtgehäuse integriert stufenlos dimmbar (DALI, Touch-Dim, Casambi). Farbtemperatur 2700K, 3000K, 3500K, 4000K, 6500K oder Tunable White. Binning initial  $\leq$  MacAdam 3. Farbwiedergabe CRI>80, CRI>90 oder Full Spectrum. Stufenlos höhenverstellbare Parallel-Seilabhangung mit transparent ummantelter Zuleitung.

**EN** LED pendant luminaire. Direct-indirect light distribution. Internal luminaire frame made of aluminium. Translucent textile fabric with special 3D folding technology and sound-absorbing characteristics, flame-retardant. The fabric can be shaped when stretched, making each luminaire unique. Powerful indirect light component can be controlled separately. Driver integrated into luminaire housing, dimmable (DALI, Touch-Dim, Casambi). Colour temperature 2700K, 3000K, 3500K, 4000K, 6500K or Tunable White. Binning  $\leq$  MacAdam 3. Colour rendering CRI>80, CRI>90 or Full Spectrum. Height-adjustable parallel cord suspension with transparent power supply cable.

**OP1 NWE-8 30 M-L1600-K**

Product Family	<b>O:</b> Kumo
Type	<b>G1:</b> Direct only, <b>P1:</b> Direct-Indirect
Optical System	<b>N:</b> Opal Fabric
Surface Finish	<b>W:</b> Snow White
Control Gear	<b>E:</b> On/Off, <b>L:</b> DALI, <b>H:</b> Touch-Dim, <b>C:</b> Casambi
Colour Rendering	<b>8:</b> CRI>80, <b>9:</b> CRI>90, <b>F:</b> Full Spectrum [except 2200K]
Colour Temperature	<b>22:</b> 2200K, <b>27:</b> 2700K, <b>30:</b> 3000K, <b>35:</b> 3500K, <b>40:</b> 4000K, <b>65:</b> 6500K, <b>TW:</b> Tunable White
Power	<b>E:</b> Low Power, <b>M:</b> Medium Power, <b>H:</b> High Power
Size	Luminaire Length in mm: <b>L1600</b>
Suspension	<b>K:</b> Parallel Suspension



Opal Fabric | Direct

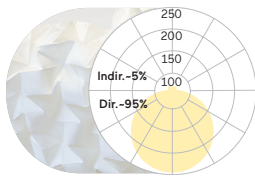

Opal Fabric | Direct-Indirect

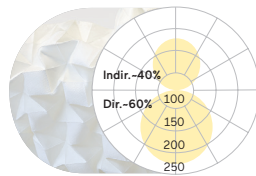

L mm	Opal Fabric   Direct			Opal Fabric   Direct-Indirect			
	Lumen/Watt Low Power	Lumen/Watt Medium Power	Lumen/Watt High Power	L mm	Lumen/Watt Low Power	Lumen/Watt Medium Power	Lumen/Watt High Power
1600	4530lm/62W	6580lm/93W	9430lm/139W	1600	7600lm/82W	11000lm/123W	15900lm/184W

Lumen Values: Luminaire luminous flux at 4000K/CRI>80. Other configurations on request.

Parallel Suspension

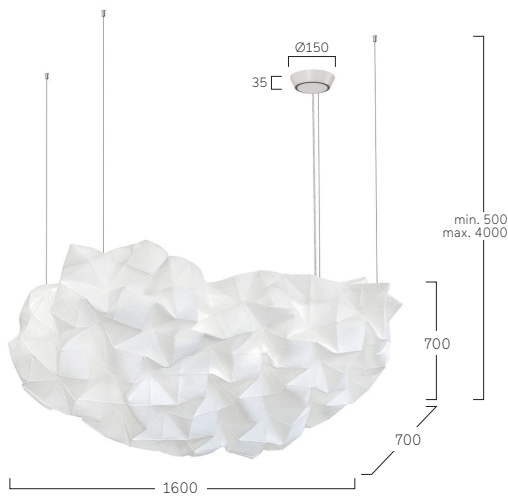

## Serenity (Round) G1/P1 | Suspended



**DE** LED-Akustik-Pendelleuchte. Direkt-indirekt oder rein direktstrahlend. Leuchtenkörper aus Aluminium. Schallabsorber für breites Frequenzspektrum zur Reduktion der Nachhallzeit. 3D-Textilstoff aus Trevira CS wahlweise in den Farben Cream, Taupe, Green und Anthracite. Direktanteil über Präzisionslinsen für rotationssymmetrische Lichtstärkeverteilung bei gleichzeitig hoher Blendungsbegrenzung ( $UGR < 19$ ) speziell für Office Anwendungen. Konverter in Leuchtengehäuse integriert, wahlweise einfach schaltbar oder stufenlos dimmbar (DALI, Touch-Dim, Casambi). Farbtemperatur 2700K, 3000K, 3500K, 4000K oder 6500K. Binning initial  $\leq$  MacAdam 3. Farbwiedergabe  $CRI > 80$ ,  $CRI > 90$  oder Full Spectrum. Stufenlos höhenverstellbare Parallel-Seilabhangung mit transparent ummantelter Zuleitung. Lackierung Baldachin passend Leuchtenkorper.

**EN** LED acoustic pendant luminaire. Direct-indirect or direct-only light distribution. Luminaire body made of aluminium. Sound absorber for a wide frequency spectrum, to reduce the reverberation time. 3D textile fabric made of Trevira CS available in cream, taupe, green and anthracite. Direct light with precision lenses for uniform symmetrical light distribution with high glare limitation ( $UGR < 19$ ) for workplaces. Driver integrated into luminaire housing, available as switched or dimmable (DALI, Touch-Dim, Casambi). Colour temperature 2700K, 3000K, 3500K, 4000K or 6500K. Binning  $\leq$  MacAdam 3. Colour rendering  $CRI > 80$ ,  $CRI > 90$  or Full Spectrum. Height-adjustable parallel cord suspension with transparent power supply cable. Ceiling rose to match luminaire body.

**FP1 K 1 E-8 30 M-D930-K**

Product Family	F: Serenity
Type	G1: Direct only, P1: Direct-Indirect
Optical System	K: Anti-Glare Lens 24°
Surface Finish	1: Cream Fabric, 2: Green Fabric, 3: Taupe Fabric, 4: Antracite Fabric
Control Gear	E: On/Off, L: DALI, H: Touch-Dim, C: Casambi
Colour Rendering	8: CRI>80, 9: CRI>90, F: Full Spectrum [except 2200K]
Colour Temperature	22: 2200K, 27: 2700K, 30: 3000K, 35: 3500K, 40: 4000K, 65: 6500K
Power	E: Low Power, M: Medium Power, H: High Power
Size	Luminaire Diameter in mm: D930
Suspension	K: Parallel Suspension, U: Central Suspension



Direct only

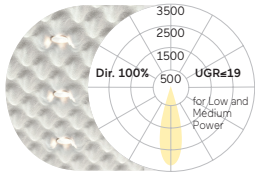

Direct-Indirect

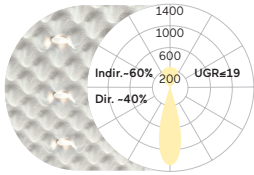

D mm	Lumen/Watt Low Power	Lumen/Watt Medium Power	Lumen/Watt High Power	D mm	Lumen/Watt Low Power	Lumen/Watt Medium Power	Lumen/Watt High Power
930	2000lm/20W	3000lm/32W	4160lm/48W	930	5100lm/40W	7700lm/62W	11060lm/93W

Lumen Values: Luminaire luminous flux at 4000K/CRI>80. Other configurations on request.

Parallel Suspension

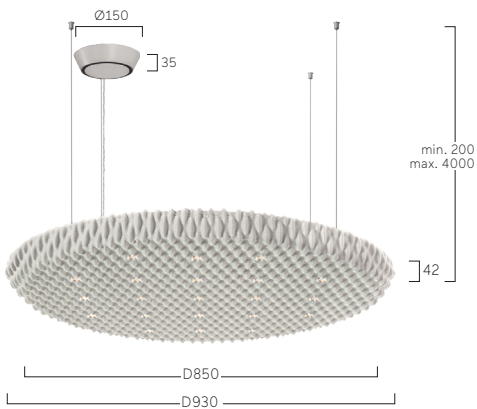

Central Suspension



1 Cream Fabric

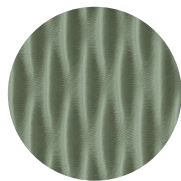

2 Green Fabric

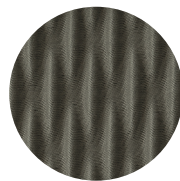

3 Taupe Fabric

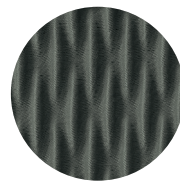

4 Antracite Fabric

## Serenity (Square) G2/P2 | Suspended



**DE** LED-Akustik-Pendelleuchte. Direkt-indirekt oder rein direktstrahlend. Leuchtenkörper aus Aluminium. Schallabsorber für breites Frequenzspektrum zur Reduktion der Nachhallzeit. 3D-Textilstoff aus Trevira CS wahlweise in den Farben Cream, Taupe, Green und Anthracite. Direktanteil über Präzisionslinsen für rotationssymmetrische Lichtstärkeverteilung bei gleichzeitig hoher Blendungsbegrenzung (UGR<19) speziell für Office Anwendungen. Konverter in Leuchtengehäuse integriert, wahlweise einfach schaltbar oder stufenlos dimmbar (DALI, Touch-Dim, Casambi). Farbtemperatur 2700K, 3000K, 3500K, 4000K oder 6500K. Binning initial  $\leq$  MacAdam 3. Farbwiedergabe CRI>80, CRI>90 oder Full Spectrum. Stufenlos höhenverstellbare Parallel-Seilabhängung mit transparent ummantelter Zuleitung. Lackierung Baldachin passend Leuchtenkörper.

**EN** LED acoustic pendant luminaire. Direct-indirect or direct-only light distribution. Luminaire body made of aluminium. Sound absorber for a wide frequency spectrum, to reduce the reverberation time. 3D textile fabric made of Trevira CS available in cream, taupe, green and anthracite. Direct light with precision lenses for uniform symmetrical light distribution with high glare limitation (UGR<19) for workplaces. Driver integrated into luminaire housing, available as switched or dimmable (DALI, Touch-Dim, Casambi). Colour temperature 2700K, 3000K, 3500K, 4000K or 6500K. Binning  $\leq$  MacAdam 3. Colour rendering CRI>80, CRI>90 or Full Spectrum. Height-adjustable parallel cord suspension with transparent power supply cable. Ceiling rose to match luminaire body.

**F P2 K1 E-8 30 M-Q930-K**

Product Family	F: Serenity
Type	G2: Direct only, P2: Direct-Indirect
Optical System	K: Anti-Glare Lens 24°
Surface Finish	1: Cream Fabric, 2: Green Fabric, 3: Taupe Fabric, 4: Antracite Fabric
Control Gear	E: On/Off, L: DALI, H: Touch-Dim, C: Casambi
Colour Rendering	8: CRI>80, 9: CRI>90, F: Full Spectrum [except 2200K]
Colour Temperature	22: 2200K, 27: 2700K, 30: 3000K, 35: 3500K, 40: 4000K, 65: 6500K
Power	E: Low Power, M: Medium Power, H: High Power
Size	Luminaire Size in mm: Q930
Suspension	K: Parallel Suspension, U: Central Suspension

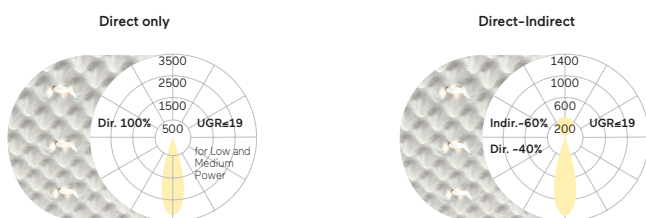

Q	Lumen/Watt	Lumen/Watt	Lumen/Watt	Q	Lumen/Watt	Lumen/Watt	Lumen/Watt
mm	Low Power	Medium Power	High Power	mm	Low Power	Medium Power	High Power
930	2850lm/28W	4250lm/44W	5940lm/68W	930	7550lm/58W	11150lm/89W	14940lm/128W

Lumen Values: Luminaire luminous flux at 4000K/CRI>80. Other configurations on request.

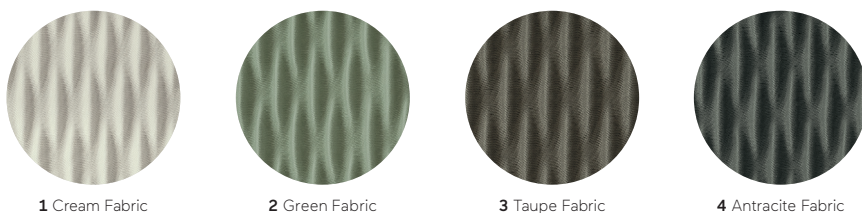
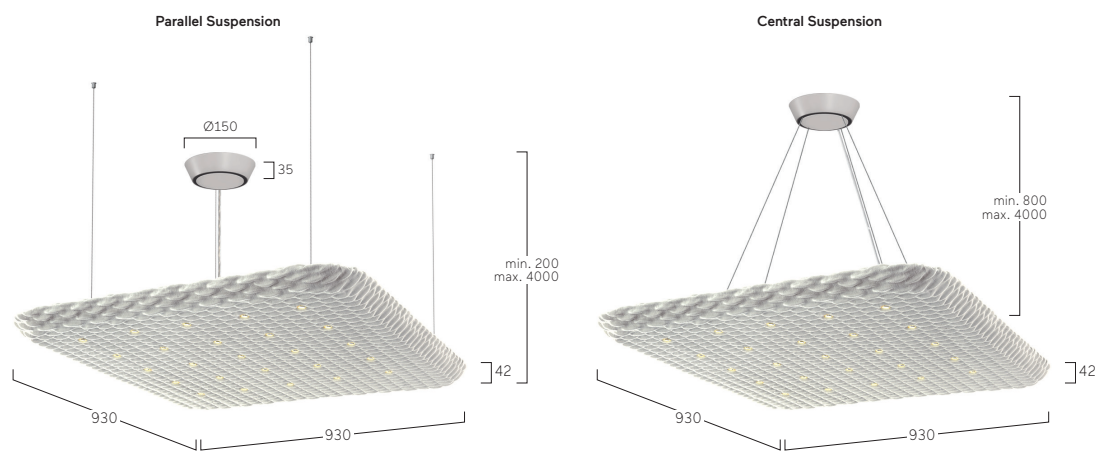



## Serenity (Rectangular) G3/P3 | Suspended



**DE** LED-Akustik-Pendelleuchte. Direkt-indirekt oder rein direktstrahlend. Leuchtenkörper aus Aluminium. Schallabsorber für breites Frequenzspektrum zur Reduktion der Nachhallzeit. 3D-Textilstoff aus Trevira CS wahlweise in den Farben Cream, Taupe, Green und Anthracite. Direktanteil über Präzisionslinsen für rotationssymmetrische Lichtstärkeverteilung bei gleichzeitig hoher Blendungsbegrenzung (UGR<19) speziell für Office Anwendungen. Konverter in Leuchtengehäuse integriert, wahlweise einfach schaltbar oder stufenlos dimmbar (DALI, Touch-Dim, Casambi). Farbtemperatur 2700K, 3000K, 3500K, 4000K oder 6500K. Binning initial  $\leq$  MacAdam 3. Farbwiedergabe CRI>80, CRI>90 oder Full Spectrum. Stufenlos höhenverstellbare Parallel-Seilabhangung mit transparent ummantelter Zuleitung. Lackierung Baldachin passend Leuchtenkorper.

**EN** LED acoustic pendant luminaire. Direct-indirect or direct-only light distribution. Luminaire body made of aluminium. Sound absorber for a wide frequency spectrum, to reduce the reverberation time. 3D textile fabric made of Trevira CS available in cream, taupe, green and anthracite. Direct light with precision lenses for uniform symmetrical light distribution with high glare limitation (UGR<19) for workplaces. Driver integrated into luminaire housing, available as switched or dimmable (DALI, Touch-Dim, Casambi). Colour temperature 2700K, 3000K, 3500K, 4000K or 6500K. Binning  $\leq$  MacAdam 3. Colour rendering CRI>80, CRI>90 or Full Spectrum. Height-adjustable parallel cord suspension with transparent power supply cable. Ceiling rose to match luminaire body.

**F P3 K 1 E- 8 30 M-L1428-K**

Product Family	F: Serenity
Type	<b>G3:</b> Direct only, <b>P3:</b> Direct-Indirect
Optical System	<b>K:</b> Anti-Glare Lens 24°
Surface Finish	<b>1:</b> Cream Fabric, <b>2:</b> Green Fabric, <b>3:</b> Taupe Fabric, <b>4:</b> Antracite Fabric
Control Gear	<b>E:</b> On/Off, <b>L:</b> DALI, <b>H:</b> Touch-Dim, <b>C:</b> Casambi
Colour Rendering	<b>8:</b> CRI>80, <b>9:</b> CRI>90, <b>F:</b> Full Spectrum [except 2200K]
Colour Temperature	<b>22:</b> 2200K, <b>27:</b> 2700K, <b>30:</b> 3000K, <b>35:</b> 3500K, <b>40:</b> 4000K, <b>65:</b> 6500K
Power	<b>E:</b> Low Power, <b>M:</b> Medium Power, <b>H:</b> High Power
Size	Luminaire Length in mm: <b>L1428</b>
Suspension	<b>K:</b> Parallel Suspension



Direct only

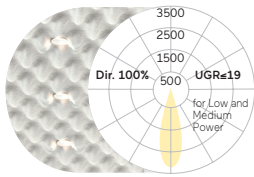

Direct-Indirect

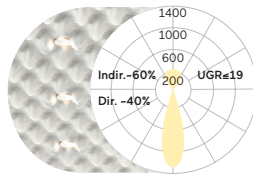

L mm	Lumen/Watt Low Power	Lumen/Watt Medium Power	Lumen/Watt High Power	L mm	Lumen/Watt Low Power	Lumen/Watt Medium Power	Lumen/Watt High Power
1428	2560lm/25W	3820lm/40W	5350lm/61W	1428	6390lm/49W	9540lm/75W	14130lm/115W

Lumen Values: Luminaire luminous flux at 4000K/CRI>80. Other configurations on request.

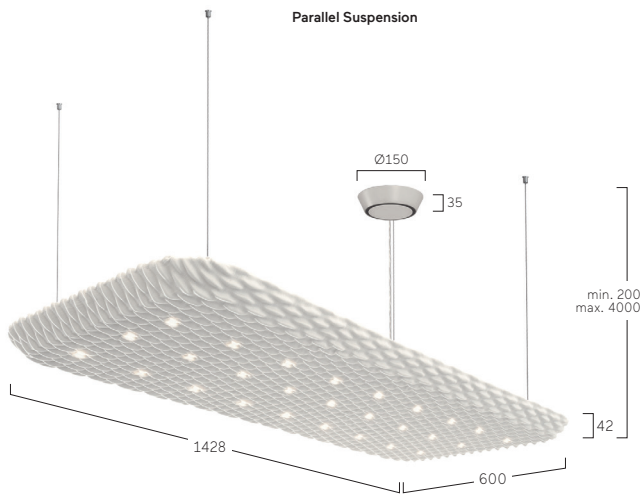

1 Cream Fabric

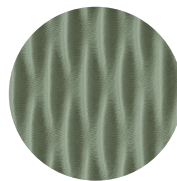

2 Green Fabric

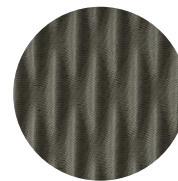

3 Taupe Fabric

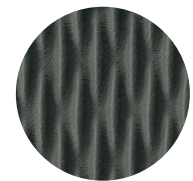

4 Antracite Fabric

# Ringo Star Acoustic Oblong S2 | Floor



**DE** LED-Akustik-Stehleuchte direkt-indirektstrahlend. Leuchtenkörper aus Aluminiumprofil mit 40mm Profilbreite. Sondermaße auf Anfrage möglich. Oberfläche weiß, silber, graphit, schwarz, kupfer oder bronzefarben lackiert. Weitere Oberflächenoptionen siehe Lightnet-Surface-Collection oder RAL nach Wahl. Innenliegender Schallabsorber für breites Frequenzspektrum zur Reduktion der Nachhallzeit. Direktanteil über Präzisionslinsen mit Abblendraster für breite rotationssymmetrische Lichtstärkeverteilung bei gleichzeitig hoher Blendungsbegrenzung (UGR<19) speziell für Office Anwendungen. Abblendraster in verschiedenen Farbkombinationen erhältlich. Intuitives Bedienfeld im Leuchtenmast für getrennt stufenlose Dimmung und Schaltung der Kammern für Direkt-/Indirektlicht, bei Tunable White oder Integration von Multisensor- oder Schwarmtechnologie gemeinsame Steuerung der Lichtkammern. Optional: HCL-Control für automatisches, dem Tagesverlauf angepasstes, biodynamisches Licht. Farbtemperatur 2200K, 2700K, 3000K, 3500K, 4000K, 6500K oder Tunable White (2700-6500K). Binning initial  $\leq$  MacAdam 3. Farbwiedergabe CRI>80, CRI>90 oder Full Spectrum. Fußplatte aus Stahl, Lackierung passend Leuchtenkörper. 4m Anschlusskabel mit länderspezifischem Stecker (EU, CH, UK).

**EN** LED acoustic free-standing luminaire. Direct-indirect light distribution. Luminaire body made of aluminium profile with 40mm profile width. Special dimensions available on request. Surface white, silver, graphite, black, copper or bronze coated. For further surface options see Lightnet-Surface-Collection or RAL of your choice. Internal sound absorber for a wide frequency spectrum, to reduce the reverberation time. Direct light using precision lenses with louvre for wide uniform symmetrical light distribution with high glare limitation (UGR<19) for workplaces. Louvre available in various colour finishes. Intuitive pole mounted control panel for dimming and switching the direct/indirect light separately, joint control of the light chambers with Tunable White or integration of multi-sensor or swarm technology. Optional: HCL Control for automatic, time dependent, biodynamic lighting. Colour temperature 2200K, 2700K, 3000K, 3500K, 4000K, 6500K or Tunable White (2700-6500K). Binning  $\leq$  MacAdam 3. Colour rendering CRI>80, CRI>90 or Full Spectrum. Steel Base plate, colour matching luminaire body. 4m power cable with country-specific plug (EU, CH, UK).

**R S2 L W X-8 30 M-01-UB-A-TF**

Product Family	<b>R:</b> Ringo Star
Type	<b>S2:</b> Direct-Indirect
Optical System	<b>L:</b> Lens Louvre*
Surface Finish	<b>W:</b> Snow White, <b>V:</b> Ivory White, <b>A:</b> Satin Silver, <b>S:</b> Radiant Silver, <b>U:</b> Urban Graphite, <b>B:</b> Jet Black, <b>X:</b> Satin Bronze, <b>K:</b> Satin Copper
Control Gear	<b>X:</b> Separately Dimmable, <b>M:</b> Multisensor, <b>R:</b> Swarm Control, <b>B:</b> HCL, <b>C:</b> Casambi
Colour Rendering	<b>8:</b> CRI>80, <b>9:</b> CRI>90, <b>F:</b> Full Spectrum [except 2200K]
Colour Temperature	<b>22:</b> 2200K, <b>27:</b> 2700K, <b>30:</b> 3000K, <b>35:</b> 3500K, <b>40:</b> 4000K, <b>65:</b> 6500K, <b>TW:</b> Tunable White 2700-6500K
Power	<b>M:</b> Medium Power
Size	Luminaire Dimension: <b>O1-</b> L772 D376
Base	<b>U:</b> U- Cut Out**
Lens Louvre*	<b>W:</b> Snow White, <b>A:</b> Satin Silver, <b>B:</b> Jet Black, <b>X:</b> Satin Bronze, <b>K:</b> Satin Copper, <b>G:</b> Satin Gold
Plug	<b>A:</b> Schuko CEE 7/7 (Type E+F), <b>B:</b> CH T12 (Type J), <b>C:</b> UK BS 1363 (Type G), <b>D:</b> Wieland, <b>E:</b> WAGO
Acoustic Absorb.	<b>CF:</b> Cream Fabric, <b>GF:</b> Green Fabric, <b>TF:</b> Taupe Fabric, <b>AF:</b> Antracite Fabric

\*\*Bases with Soft Corners



**Lens Louvre | Direct-Indirect**

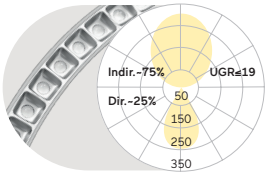

**Lumen/Watt**  
**Medium Power**  
11700lm/78W

Lumen Values: Luminaire luminous flux at 4000K/CRI>80. Other configurations on request.

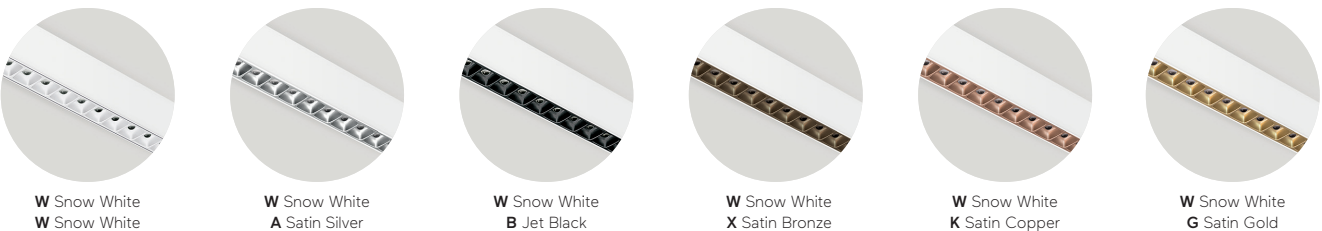
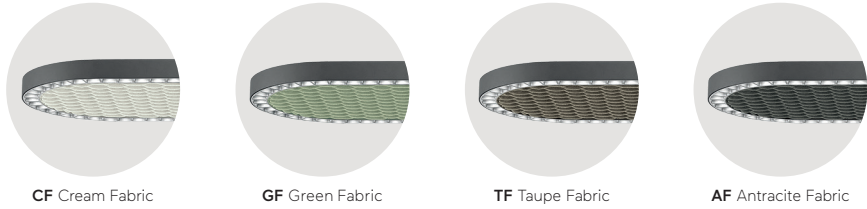
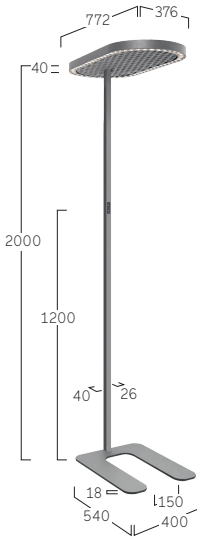

## Ringo Star Acoustic Oblong GY/PY | Suspended



**DE** LED-Akustik-Pendelleuchte. Direkt-indirekt oder rein direktstrahlend. Leuchtenkörper aus Aluminiumprofil mit 40mm Profildbreite. Sondermaße auf Anfrage möglich. Oberfläche weiß, silber, graphit, schwarz, kupfer oder bronzefarben lackiert. Weitere Oberflächenoptionen siehe Lightnet-Surface-Collection oder RAL nach Wahl. Innenliegender Schallabsorber für breites Frequenzspektrum zur Reduktion der Nachhallzeit. Direktanteil über Präzisionslinsen mit Abblenderaster für breite rotationssymmetrische Lichtstärkeverteilung bei gleichzeitig hoher Blendungsbegrenzung (UGR<19) speziell für Office Anwendungen. Abblenderaster in verschiedenen Farbkombinationen erhältlich. Satinierter Opaldiffusor für Allgemeinbeleuchtung mit max. Transmissionsgrad und homogener Lichtpunktauflösung. Konverter in Leuchtengehäuse integriert, wahlweise einfach schaltbar oder stufenlos dimmbar (DALI, Touch-Dim, Casambi). Farbtemperatur 2200K, 2700K, 3000K, 3500K, 4000K oder 6500K. Binning initial  $\leq$  MacAdam 3. Farbwiedergabe CRI>80, CRI>90 oder Full Spectrum. Stufenlos höhenverstellbare Parallel-Seilabhängung mit transparent ummantelter Zuleitung. Lackierung Baldachin passend Leuchtenkörper.

**EN** LED acoustic pendant luminaire. Direct-indirect or direct-only light distribution. Luminaire body made of aluminium profile with 40mm profile width. Special dimensions available on request. Surface white, silver, graphite, black, copper or bronze coated. For further surface options see Lightnet-Surface-Collection or RAL of your choice. Internal sound absorber for a wide frequency spectrum, to reduce the reverberation time. Direct light using precision lenses with louvre for wide uniform symmetrical light distribution with high glare limitation (UGR<19) for workplaces. Louvre available in various colour finishes. Satin opal diffuser for general lighting with maximum transmittance and uniformity. Driver integrated into luminaire housing, available as switched or dimmable (DALI, Touch-Dim, Casambi). Colour temperature 2200K, 2700K, 3000K, 3500K, 4000K or 6500K. Binning  $\leq$  MacAdam 3. Colour rendering CRI>80, CRI>90 or Full Spectrum. Height-adjustable parallel cord suspension with transparent power supply cable. Ceiling rose to match luminaire body.

**R PYL WE-8 30 M-O61 - KB\*-TF**

Product Family **R:** Ringo Star

Type **GY:** Direct only, **PY:** Direct-Indirect,

Optical System **C:** Opal Flex Diffuser, **L:** Lens Louvre\*

Surface Finish **W:** Snow White, **V:** Ivory White, **A:** Satin Silver, **S:** Radiant Silver,  
**U:** Urban Graphite, **B:** Jet Black, **X:** Satin Bronze, **K:** Satin Copper

Control Gear **E:** On/Off, **L:** DALI, **C:** Casambi, **H:** Touch-Dim

Colour Rendering **8:** CRI>80, **9:** CRI>90, **F:** Full Spectrum [except 2200K]

Colour Temperature **22:** 2200K, **27:** 2700K, **30:** 3000K, **35:** 3500K, **40:** 4000K, **65:** 6500K

Power **E:** Low Power, **M:** Medium Power, **H:** High Power

Size Luminaire Dimension: **O61-** L1790 D600, **O62-** L2450 D600, **O91-** L1820 D900, **O92-** L2480 D900

Suspension **K:** Parallel Suspension

Lens Louvre\* **W:** Snow White, **A:** Satin Silver, **B:** Jet Black, **X:** Satin Bronze, **K:** Satin Copper, **G:** Satin Gold

Acoustic Absorb. **AM:** Green Moss, **CF:** Cream Fabric, **GF:** Green Fabric, **TF:** Taupe Fabric, **AF:** Antracite Fabric,  
**AW:** Micro Perforated, **BW:** Beige Wool, **ZW:** Green Wool, **GW:** Graphite Wool



Lens Louvre   Direct-Indirect			Lens Louvre   Direct			Opal Flex Diffuser   Direct-Indirect			Opal Flex Diffuser   Direct		
Type	Lumen/Watt Low Power	Lumen/Watt Medium Power	Type	Lumen/Watt Low Power	Lumen/Watt High Power	Type	Lumen/Watt Low Power	Lumen/Watt Medium Power	Type	Lumen/Watt Medium Power	Lumen/Watt High Power
O61	13590lm/100W	19000lm/145W	O61	6950lm/53W	12680lm/102W	O61	11130lm/93W	15410lm/133W	O61	6250lm/64W	8880lm/92W
O62	17950lm/134W	25130lm/189W	O62	9180lm/71W	16780lm/133W	O62	14680lm/122W	20320lm/171W	O62	8240lm/81W	11730lm/121W
O91	14870lm/107W	20760lm/156W	O91	7600lm/55W	13930lm/109W	O91	12150lm/103W	16740lm/143W	O91	6800lm/70W	9610lm/101W
O92	19240lm/139W	26870lm/201W	O92	9840lm/73W	18030lm/148W	O92	15700lm/130W	21660lm/182W	O92	8790lm/88W	12460lm/130W

Lumen Values: Luminaire luminous flux at 4000K/CRI>80. Other configurations on request.

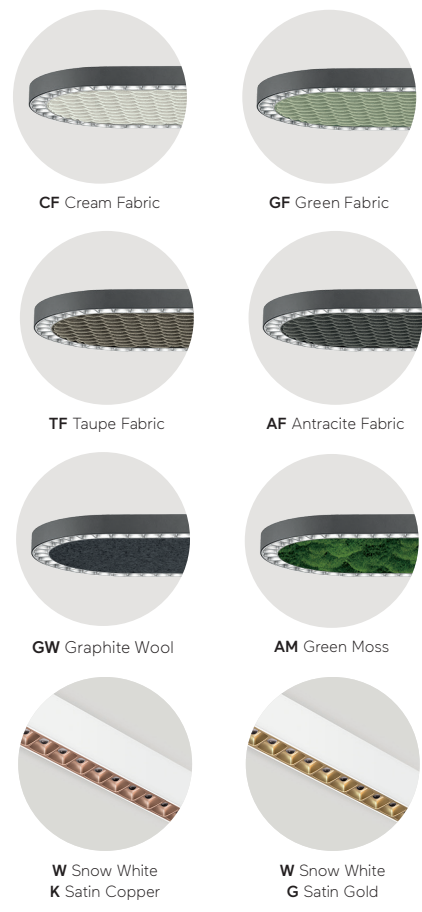
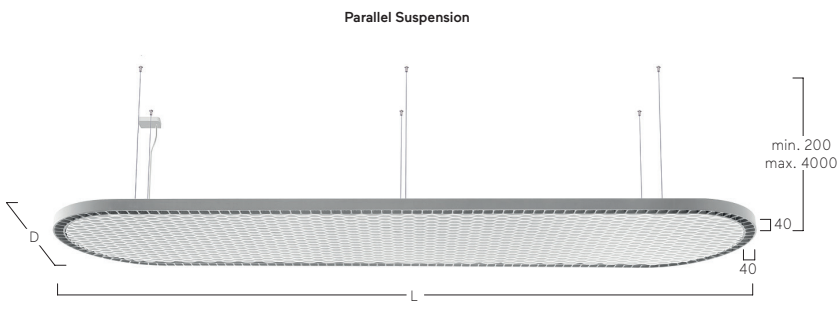

## Beam Me Up (Soft Edge) S2 | Floor



**DE** LED-Stehleuchte mit rückversetzter Optik und dekorativem Reflektorring. Direkt-indirektstrahlend. Leuchtschirm aus hochwertig verarbeiteten Kunstguss. Gehäuse-Außenfläche und Innendekor in unterschiedlichen Lackierungen und Kombinationen erhältlich, z.B. weiß, silber, graphit, schwarz, gold oder kupferfarben lackiert. Zu Oberflächenoptionen- und Kombinationen siehe Lightnet-Surface-Collection oder Bi-Colour-Auswahl. Microprismenoptik mit optimierter Blendungsbegrenzung speziell für Office-Anwendungen. Satiniertes Opaldiffusor für Allgemeinbeleuchtung mit max. Transmissionsgrad und homogener Lichtpunktauflösung. Intuitives Bedienfeld im Leuchtenmast für getrennt stufenlose Dimmung und Schaltung der Kammern für Direkt-/Indirektlicht, bei Tunable White oder Integration von Multisensor- oder Schwarmtechnologie gemeinsame Steuerung der Lichtkammern. Optional: HCL-Control für automatisches, dem Tagesverlauf angepasstes, biodynamisches Licht. Farbtemperatur 2200K, 2700K, 3000K, 3500K, 4000K, 6500K oder Tunable White (2700-6500K). Binning initial  $\leq$  MacAdam 3. Farbwiedergabe CRI>80, CRI>90 oder Full Spectrum. Fußplatte aus Stahl, Lackierung passend Leuchtenkörper. 4m Anschlusskabel mit länderspezifischem Stecker (EU, CH, UK).

**EN** LED free-standing luminaire with a rebated lens optic in a decorative ring. Direct-indirect light distribution. Luminaire shade made of high-quality processed synthetic cast. Outer housing and inner decor available in various finishes and combinations, e.g. white, silver, graphite, black, gold or copper coated. For surface options and combinations, see Lightnet-Surface-Collection or Bi-Colour selection. Microprismatic screen with optimized glare reduction for workplaces. Satin opal diffuser for general lighting with maximum transmittance and uniformity. Intuitive pole mounted control panel for dimming and switching the direct/indirect light separately, joint control of the light chambers with Tunable White or integration of multi-sensor or swarm technology. Optional: HCL Control for automatic, time dependent, biodynamic lighting. Colour temperature 2200K, 2700K, 3000K, 3500K, 4000K, 6500K or Tunable White (2700-6500K). Binning  $\leq$  MacAdam 3. Colour rendering CRI>80, CRI>90 or Full Spectrum. Steel Base plate, colour matching luminaire body. 4m power cable with country-specific plug (EU, CH, UK).

**M S2 A B X-8 30M-L640-UG-A**

Product Family	<b>M:</b> Beam Me Up
Type	<b>S2:</b> Direct-Indirect
Optical System	<b>A:</b> Microprismatic, <b>O:</b> Opal Diffuser
Surface Finish	<b>W:</b> Snow White, <b>V:</b> Ivory White, <b>A:</b> Satin Silver, <b>U:</b> Urban Graphite, <b>B:</b> Jet Black, <b>X:</b> Satin Bronze, <b>K:</b> Satin Copper
Control Gear	<b>X:</b> Separately Dimmable, <b>M:</b> Multisensor, <b>R:</b> Swarm Control, <b>B:</b> HCL, <b>C:</b> Casambi
Colour Rendering	<b>8:</b> CRI>80, <b>9:</b> CRI>90, <b>F:</b> Full Spectrum [except 2200K]
Colour Temperature	<b>22:</b> 2200K, <b>27:</b> 2700K, <b>30:</b> 3000K, <b>35:</b> 3500K, <b>40:</b> 4000K, <b>65:</b> 6500K, <b>TW:</b> Tunable White 2700-6500K
Power	<b>M:</b> Medium Power
Size	Head Length in mm: <b>640 x 340</b>
Base*	<b>U:</b> U-Cut Out**
Reflector	<b>W:</b> Snow White, <b>V:</b> Ivory White, <b>A:</b> Satin Silver, <b>U:</b> Urban Graphite, <b>B:</b> Jet Black, <b>X:</b> Satin Bronze, <b>K:</b> Satin Copper, <b>G:</b> Satin Gold
Plug	<b>A:</b> Schuko CEE 7/7 (Type E+F), <b>B:</b> CH T12 (Type J), <b>C:</b> UK BS 1363 (Type G), <b>D:</b> Wieland, <b>E:</b> WAGO

\*\*Bases with Soft Corners



**Microprismatic | Direct-Indirect**

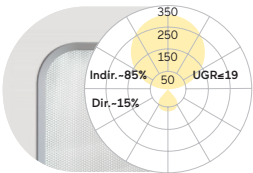

**Opal Diffuser | Direct-Indirect**

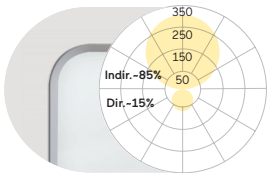

L	Lumen/Watt	Lumen/Watt	L	Lumen/Watt	Lumen/Watt
mm	Medium Power	High Power	mm	Medium Power	High Power
600	11000lm/73W	14500lm/96W	600	10700lm/73W	14200lm/96W

Lumen Values: Luminaire luminous flux at 4000K/CRI>80. Other configurations on request.

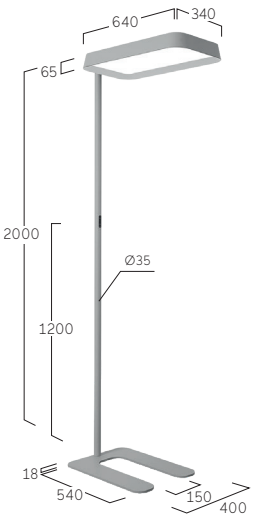

Multisensor / HCL / Swarm Control



Separately Dimmable



**W** Snow White  
**B** Jet Black



**M** Satin Cloud  
**M** Satin Cloud



**X** Satin Bronze  
**B** Jet Black



**B** Jet Black  
**S** Satin Silver

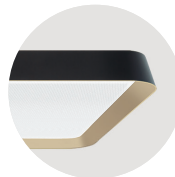

**B** Jet Black  
**G** Satin Gold

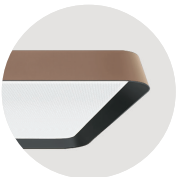

**K** Satin Copper  
**B** Jet Black



## Beam Me Up (Soft Edge) S5 | Floor



**DE** LED-Stehleuchte mit rückversetzter Optik und dekorativem Reflektorring. Direkt-indirektstrahlend. Leuchterschirm aus hochwertig verarbeitetem Kunstguss. Gehäuse-Außenfläche und Innendekor in unterschiedlichen Lackierungen und Kombinationen erhältlich, z.B. weiß, silber, graphit, schwarz, gold oder kupferfarben lackiert. Zu Oberflächenoptionen- und Kombinationen siehe Lightnet-Surface-Collection oder Bi-Colour-Auswahl. Microprismenoptik mit optimierter Blendungsbegrenzung speziell für Office-Anwendungen. Satiniertes Opaldiffusor für Allgemeinbeleuchtung mit max. Transmissionsgrad und homogener Lichtpunktauflösung. Intuitives Bedienfeld im Leuchtenmast für getrennt stufenlose Dimmung und Schaltung der Kammern für Direkt-/Indirektlicht, bei Tunable White oder Integration von Multisensor- oder Schwarmtechnologie gemeinsame Steuerung der Lichtkammern. Optional: HCL-Control für automatisches, dem Tagesverlauf angepasstes, biodynamisches Licht. Farbtemperatur 2200K, 2700K, 3000K, 3500K, 4000K, 6500K oder Tunable White (2700-6500K). Binning initial  $\leq$  MacAdam 3. Farbwiedergabe CRI $>$ 80, CRI $>$ 90 oder Full Spectrum. Fußplatte aus Stahl, Lackierung passend Leuchtenkörper. 4m Anschlusskabel mit länderspezifischem Stecker (EU, CH, UK).

**EN** LED free-standing luminaire with a rebated lens optic in a decorative ring. Direct-indirect light distribution. Luminaire shade made of high-quality processed synthetic cast. Outer housing and inner decor available in various finishes and combinations, e.g. white, silver, graphite, black, gold or copper coated. For surface options and combinations, see Lightnet-Surface-Collection or Bi-Colour selection. Microprismatic screen with optimized glare reduction for workplaces. Satin opal diffuser for general lighting with maximum transmittance and uniformity. Intuitive pole mounted control panel for dimming and switching the direct/indirect light separately, joint control of the light chambers with Tunable White or integration of multi-sensor or swarm technology. Optional: HCL Control for automatic, time dependent, biodynamic lighting. Colour temperature 2200K, 2700K, 3000K, 3500K, 4000K, 6500K or Tunable White (2700-6500K). Binning  $\leq$  MacAdam 3. Colour rendering CRI $>$ 80, CRI $>$ 90 or Full Spectrum. Steel Base plate, colour matching luminaire body. 4m power cable with country-specific plug (EU, CH, UK).

**MS5 A B X-8 30 M-Q640-CG-A**

Product Family	<b>M:</b> Beam Me Up
Type	<b>S5:</b> Direct-Indirect
Optical System	<b>A:</b> Microprismatic, <b>O:</b> Opal Diffuser
Surface Finish	<b>W:</b> Snow White, <b>V:</b> Ivory White, <b>A:</b> Satin Silver, <b>U:</b> Urban Graphite, <b>B:</b> Jet Black, <b>X:</b> Satin Bronze, <b>K:</b> Satin Copper
Control Gear	<b>X:</b> Separately Dimmable, <b>M:</b> Multisensor, <b>R:</b> Swarm Control, <b>B:</b> HCL, <b>C:</b> Casambi
Colour Rendering	<b>8:</b> CRI>80, <b>9:</b> CRI>90, <b>F:</b> Full Spectrum [except 2200K]
Colour Temperature	<b>22:</b> 2200K, <b>27:</b> 2700K, <b>30:</b> 3000K, <b>35:</b> 3500K, <b>40:</b> 4000K, <b>65:</b> 6500K, <b>TW:</b> Tunable White 2700-6500K
Power	<b>M:</b> Medium Power
Size	Square Size in mm: <b>Q640</b>
Base	<b>C:</b> Square*
Reflector	<b>W:</b> Snow White, <b>V:</b> Ivory White, <b>A:</b> Satin Silver, <b>U:</b> Urban Graphite, <b>B:</b> Jet Black, <b>X:</b> Satin Bronze, <b>K:</b> Satin Copper, <b>G:</b> Satin Gold
Plug	<b>A:</b> Schuko CEE 7/7 (Type E+F), <b>B:</b> CH T12 (Type J), <b>C:</b> UK BS 1363 (Type G), <b>D:</b> Wieland, <b>E:</b> WAGO

\*Bases with Soft Corners



**Microprismatic | Direct-Indirect**

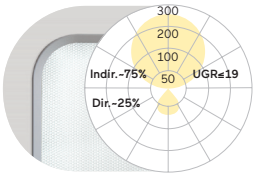

**Q** Lumen/Watt  
mm Medium Power  
640 17600lm/115W

**Opal Diffuser | Direct-Indirect**

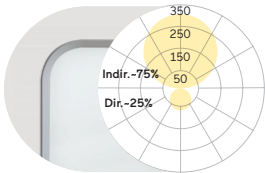

**Q** Lumen/Watt  
mm Medium Power  
640 17400lm/115W

Lumen Values: Luminaire luminous flux at 4000K/CRI>80. Other configurations on request.

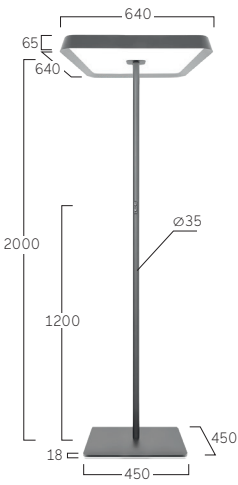

Multisensor/HCL /Swarm Control



Separately Dimmable



**W** Snow White  
**B** Jet Black

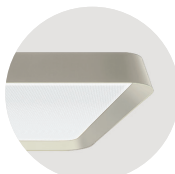

**M** Satin Cloud  
**M** Satin Cloud



**X** Satin Bronze  
**B** Jet Black



**B** Jet Black  
**S** Satin Silver

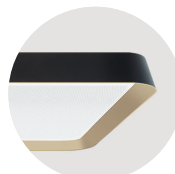

**B** Jet Black  
**G** Satin Gold

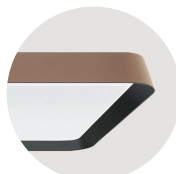

**K** Satin Copper  
**B** Jet Black

## Beam Me Up (Soft Edge) S7 | Floor



**DE** LED-Stehleuchte mit rückversetzter Optik und Innendekor. Direkt-indirektstrahlend. Leuchterschirm aus hochwertig verarbeitetem Kunstguss. Gehäuse-Außenfläche und dekorativer Reflektorring in unterschiedlichen Lackierungen und Kombinationen erhältlich, z.B. weiß, silber, graphit, schwarz, gold oder kupferfarben lackiert. Zu Oberflächenoptionen- und Kombinationen siehe Lightnet-Surface-Collection oder Bi-Colour-Auswahl. Microprismenoptik mit optimierter Blendungsbegrenzung speziell für Office-Anwendungen. Satinierter Opaldiffusor für Allgemeinbeleuchtung mit max. Transmissionsgrad und homogener Lichtpunktauflösung. Intuitives Bedienfeld im Leuchtenmast für getrennt stufenlose Dimmung und Schaltung der Kammern für Direkt-/Indirektlicht, bei Tunable White gemeinsame Steuerung der Lichtkammern. Farbtemperatur 2200K, 2700K, 3000K, 3500K, 4000K, 6500K oder Tunable White (2700-6500K). Binning initial  $\leq$  MacAdam 3. Farbwiedergabe CRI $>$ 80, CRI $>$ 90 oder Full Spectrum. Fußplatte aus Stahl, Lackierung passend Leuchtenkörper. 4m Anschlusskabel mit länderspezifischem Stecker (EU, CH, UK).

**EN** LED free-standing luminaire with rebated lens optic and inner decor. Direct-indirect light distribution. Luminaire shade made of high-quality processed synthetic cast. Outer housing and decorative reflector ring available in various finishes and combinations, e.g. white, silver, graphite, black, gold or copper coated. For surface options and combinations, see Lightnet-Surface-Collection or Bi-Colour selection. Microprismatic screen with optimized glare reduction for workplaces. Satin opal diffuser for general lighting with maximum transmittance and uniformity. Intuitive control panel in luminaire pole for dimming and switching the direct/indirect light separately, for Tunable White common control of the light chambers. Colour temperature 2200K, 2700K, 3000K, 3500K, 4000K, 6500K or Tunable White (2700-6500K). Binning $\leq$  MacAdam 3. Colour rendering CRI $>$ 80, CRI $>$ 90 or Full Spectrum. Steel Base plate, colour matching luminaire body. 4m power cable with country-specific plug (EU, CH, UK).

**MS7ABX-830M-Q640-UG-A**

Product Family	<b>M</b> : Beam Me Up
Type	<b>S7</b> : Direct-Indirect
Optical System	<b>A</b> : Microprismatic, <b>O</b> : Opal Diffuser
Surface Finish	<b>W</b> : Snow White, <b>V</b> : Ivory White, <b>A</b> : Satin Silver, <b>U</b> : Urban Graphite, <b>B</b> : Jet Black, <b>X</b> : Satin Bronze, <b>K</b> : Satin Copper
Control Gear	<b>X</b> : Separately Dimmable, <b>M</b> : Multisensor, <b>R</b> : Swarm Control, <b>B</b> : HCL, <b>C</b> : Casambi
Colour Rendering	<b>8</b> : CRI>80, <b>9</b> : CRI>90, <b>F</b> : Full Spectrum [except 2200K]
Colour Temperature	<b>22</b> : 2200K, <b>27</b> : 2700K, <b>30</b> : 3000K, <b>35</b> : 3500K, <b>40</b> : 4000K, <b>65</b> : 6500K, <b>TW</b> : Tunable White 2700-6500K
Power	<b>M</b> : Medium Power
Size	Square Size in mm: <b>Q640</b>
Base	<b>U</b> : U-Cut-Out*, <b>C</b> : Square*
Reflector	<b>W</b> : Snow White, <b>V</b> : Ivory White, <b>A</b> : Satin Silver, <b>U</b> : Urban Graphite, <b>B</b> : Jet Black, <b>X</b> : Satin Bronze, <b>K</b> : Satin Copper, <b>G</b> : Satin Gold
Plug	<b>A</b> : Schuko CEE 7/7 (Type E+F), <b>B</b> : CH T12 (Type J), <b>C</b> : UK BS 1363 (Type G), <b>D</b> : Wieland, <b>E</b> : WAGO

\*Bases with Soft Corners



**Microprismatic | Direct-Indirect**

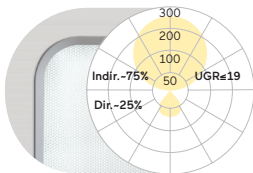

**Q** Lumen/Watt  
mm Medium Power  
640 17600lm/115W

**Opal Diffuser | Direct-Indirect**

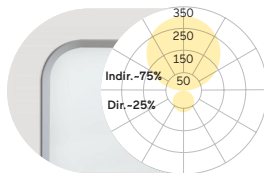

**Q** Lumen/Watt  
mm Medium Power  
640 17400lm/115W

Lumen Values: Luminaire luminous flux at 4000K/CRI>80. Other configurations on request.

**U-Cut-Out Base**



**Square Base**

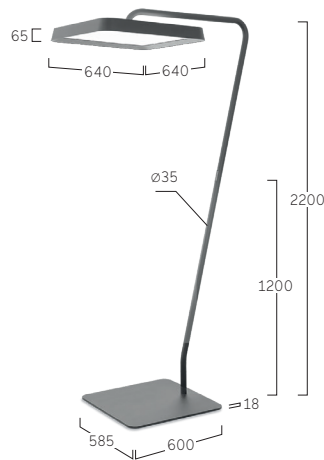

Multisensor / HCL / Swarm Control



Separately Dimmable



**W** Snow White  
**B** Jet Black

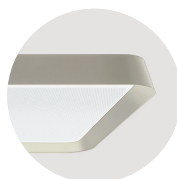

**M** Satin Cloud  
**M** Satin Cloud



**X** Satin Bronze  
**B** Jet Black



**B** Jet Black  
**S** Satin Silver

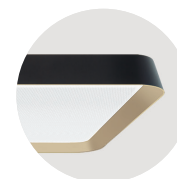

**B** Jet Black  
**G** Satin Gold

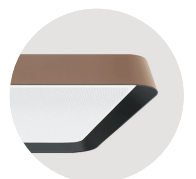

**K** Satin Copper  
**B** Jet Black

## Beam Me Up (Soft Edge) G7/P7 | Suspended



**DE** LED-Pendelleuchte mit rückversetzter Optik und dekorativem Reflektorring. Direkt-indirekt oder rein direktstrahlend. Leuchterschirm aus hochwertig verarbeitetem, glasfaserverstärktem Fiberglas. Gehäuse-Außenfläche und dekorativer Reflektorring in unterschiedlichen Lackierungen und Kombinationen erhältlich, z.B. weiß, silber, graphit, schwarz, gold oder kupferfarben lackiert. Zu Oberflächenoptionen- und Kombinationen siehe Lightnet-Surface-Collection oder Bi-Colour-Auswahl. Microprismenoptik mit optimierter Blendungsbegrenzung speziell für Office-Anwendungen. Satinierter Opaldiffusor für Allgemeinbeleuchtung mit max. Transmissionsgrad und homogener Lichtpunktauflösung. Konverter in Leuchtengehäuse integriert, wahlweise einfach schaltbar oder stufenlos dimmbar (DALI, Touch-Dim, Casambi). Farbtemperatur 2200K, 2700K, 3000K, 3500K, 4000K, 6500K oder Tunable White (2700-6500K). Binning initial  $\leq$  MacAdam 3. Farbwiedergabe CRI $>$ 80 oder CRI $>$ 90. Stufenlos höhenverstellbare Zentral-Seilabhangung (max.  $\varnothing$ 1500) oder Parallel-Seilabhangung mit transparent ummantelter Zuleitung, alternativ Pendelrohrabhangung (D400-D700). Lackierung Baldachin und Pendelrohr passend Leuchtenkorper. Auf Anfrage: Integration von Notlichtkomponenten, Sensortechnologie.

**EN** LED pendant luminaire with a rebated lens optic in a decorative ring. Direct-indirect or direct-only light distribution. Luminaire shade made of high-quality processed FRP (fiberglass reinforced plastic). Outer housing and decorative reflector ring available in various finishes and combinations, e.g. white, silver, graphite, black, gold or copper coated. For surface options and combinations, see Lightnet-Surface-Collection or Bi-Colour selection. Microprismatic screen with optimized glare reduction for workplaces. Satin opal diffuser for general lighting with maximum transmittance and uniformity. Driver integrated into luminaire housing available as switched or dimmable (DALI, Touch-Dim, Casambi). Colour temperature 2200K, 2700K, 3000K, 3500K, 4000K, 6500K or Tunable White (2700-6500K). Binning  $\leq$  MacAdam 3. Colour rendering CRI $>$ 80 or CRI $>$ 90. Height-adjustable central cord suspension (max.  $\varnothing$ 1500), parallel cord suspension with transparent power supply cable or rod suspension (D400-D700). Ceiling rose and rod suspension colours to match luminaire body. On request: Integration of emergency lighting components, sensor technology.

**M P7 A B L-8 30 M-Q640-KG**

Product Family **M:** Beam Me Up

Type **G7:** Direct only, **P7:** Direct-Indirect

Optical System **A:** Microprismatic, **O:** Opal Diffuser

Surface Finish **W:** Snow White, **V:** Ivory White, **A:** Satin Silver, **U:** Urban Graphite, **B:** Jet Black, **X:** Satin Bronze, **K:** Satin Copper

Control Gear **E:** On/Off, **L:** DALI, **H:** Touch-Dim, **C:** Casambi, **6:** DALI DT6 for TW, **8:** DALI DT8 for TW

Colour Rendering **8:** CRI>80, **9:** CRI>90, **F:** Full Spectrum [except 2200K]

Colour Temperature **22:** 2200K, **27:** 2700K, **30:** 3000K, **35:** 3500K, **40:** 4000K, **65:** 6500K, **TW:** Tunable White 2700-6500K [Q640-Q840]

Power **M:** Medium Power, **H:** High Power

Size Square Size in mm: **Q440, Q640, Q840**

Suspension **P:** Tube Suspension, **K:** Parallel Suspension, **U:** Central Suspension

Reflector **W:** Snow White, **V:** Ivory White, **A:** Satin Silver, **U:** Urban Graphite, **B:** Jet Black, **X:** Satin Bronze, **K:** Satin Copper, **G:** Satin Gold

On Request Radar Sensor, Emergency Module [Q640-Q840]



Microprismatic   Direct-Indirect			Microprismatic   Direct			Opal Diffuser   Direct-Indirect			Opal Diffuser   Direct		
Q mm	Lumen/Watt Medium Power	Lumen/Watt High Power	Q mm	Lumen/Watt Medium Power	Lumen/Watt High Power	Q mm	Lumen/Watt Medium Power	Lumen/Watt High Power	Q mm	Lumen/Watt Medium Power	Lumen/Watt High Power
440	2930lm/23W	3890lm/31W	440	2060lm/18W	2720lm/23W	440	2950lm/23W	3910lm/31W	440	2080lm/18W	2740lm/23W
640	6790lm/54W	9230lm/73W	640	4800lm/39W	6480lm/53W	640	6830lm/54W	9290lm/73W	640	4840lm/39W	6540lm/53W
840	10780lm/86W	14900lm/121W	840	7720lm/65W	10450lm/90W	840	10840lm/86W	14990lm/121W	840	7780lm/65W	10540lm/90W

Lumen Values: Luminaire luminous flux at 4000K/CRI>80. Other configurations on request.

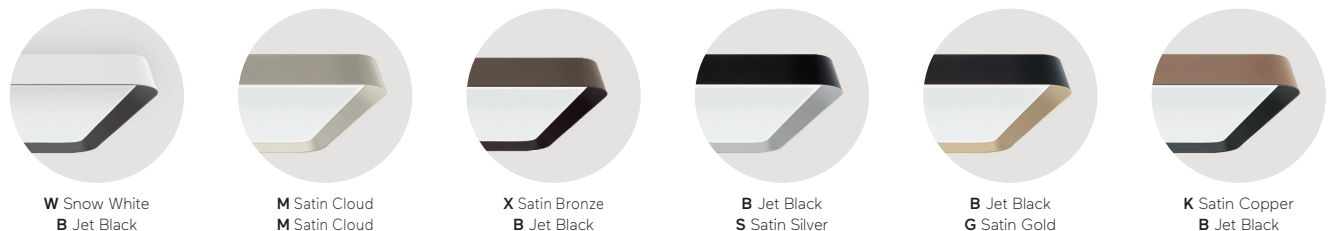
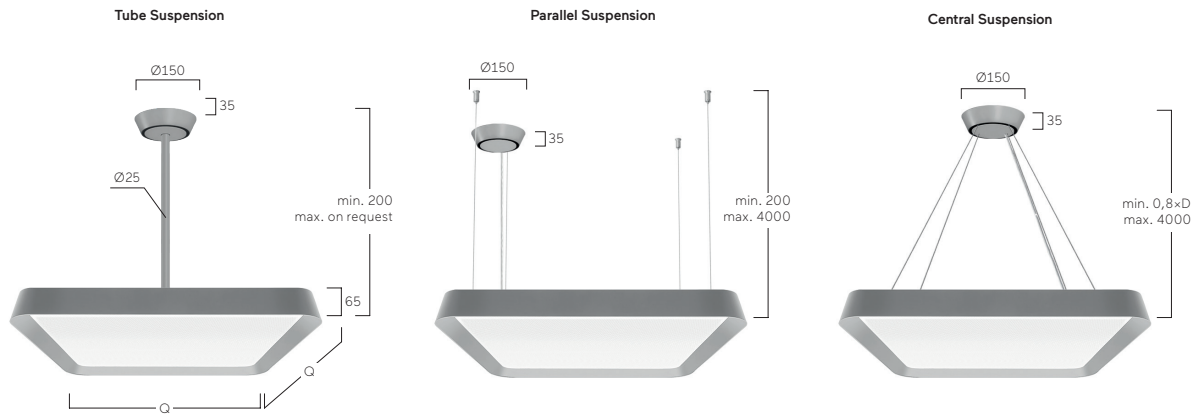

## Beam Me Up (Soft Edge) G8/P8 | Suspended



**DE** LED-Pendelleuchte mit rückversetzter Optik und dekorativem Reflektorring. Direkt-indirekt oder rein direktstrahlend. Leuchtschirm aus hochwertig verarbeitetem, glasfaserverstärktem Kunstguss. Gehäuse-Außenfläche und dekorativer Reflektorring in unterschiedlichen Lackierungen und Kombinationen erhältlich, z.B. weiß, silber, graphit, schwarz, gold oder kupferfarben lackiert. Zu Oberflächenoptionen- und Kombinationen siehe Lightnet-Surface-Collection oder Bi-Colour-Auswahl. Microprismenoptik mit optimierter Blendungsbegrenzung speziell für Office-Anwendungen. Satiniertes Opaldiffusor für Allgemeinbeleuchtung mit max. Transmissionsgrad und homogener Lichtpunktauflösung. Konverter in Leuchtengehäuse integriert, wahlweise einfach schaltbar oder stufenlos dimmbar (DALI, Touch-Dim, Casambi). Farbtemperatur 2200K, 2700K, 3000K, 3500K, 4000K, 6500K oder Tunable White (2700-6500K). Binning initial  $\leq$  MacAdam 3. Farbwiedergabe CRI>80 oder CRI>90. Stufenlos höhenverstellbare Zentral-Seilabhangung oder Parallel-Seilabhangung mit transparent ummantelter Zuleitung, alternativ Pendelrohrabhangung. Lackierung Baldachin und Pendelrohr passend Leuchtenkorper. Auf Anfrage: Integration von Notlichtkomponenten, Sensortechnologie.

**EN** LED pendant luminaire with a rebated lens optic in a decorative ring. Direct-indirect or direct-only light distribution. Luminaire shade made of high-quality, fibre-glass-reinforced synthetic cast. Outer housing and decorative reflector ring available in various finishes and combinations, e.g. white, silver, graphite, black, gold or copper coated. For surface options and combinations, see Lightnet-Surface-Collection or Bi-Colour selection. Microprismatic screen with optimized glare reduction for workplaces. Satin opal diffuser for general lighting with maximum transmittance and homogeneous lighting. Driver integrated into luminaire housing, available as switched or dimmable (DALI, Touch-Dim, Casambi). Colour temperature 2200K, 2700K, 3000K, 3500K, 4000K, 6500K or Tunable White (2700-6500K). Binning  $\leq$  MacAdam 3. Colour rendering CRI>80 or CRI>90. Height-adjustable central cord suspension, parallel cord suspension with transparent power supply cable or rod suspension. Ceiling rose and rod suspension colour to match luminaire body. On request: Integration of emergency lighting components and sensor technology.

**M P8 O A L-8 30 M-L990-UG**

Product Family	<b>M:</b> Beam Me Up
Type	<b>G8:</b> Direct only, <b>P8:</b> Direct-Indirect
Optical System	<b>A:</b> Microprismatic, <b>O:</b> Opal Diffuser
Surface Finish	<b>W:</b> Snow White, <b>V:</b> Ivory White, <b>A:</b> Satin Silver, <b>U:</b> Urban Graphite, <b>B:</b> Jet Black, <b>X:</b> Satin Bronze, <b>K:</b> Satin Copper
Control Gear	<b>E:</b> On/Off, <b>L:</b> DALI, <b>H:</b> Touch-Dim, <b>C:</b> Casambi, <b>6:</b> DALI DT6 for TW, <b>8:</b> DALI DT8 for TW
Colour Rendering	<b>8:</b> CRI>80, <b>9:</b> CRI>90, <b>F:</b> Full Spectrum [except 2200K]
Colour Temperature	<b>22:</b> 2200K, <b>27:</b> 2700K, <b>30:</b> 3000K, <b>35:</b> 3500K, <b>40:</b> 4000K, <b>65:</b> 6500K, <b>TW:</b> Tunable White 2700-6500K
Power	<b>M:</b> Medium Power, <b>H:</b> High Power
Size	Luminaire Length in mm: <b>L990, L1290, L1590</b>
Suspension	<b>P:</b> Tube Suspension, <b>K:</b> Parallel Suspension
Reflector	<b>W:</b> Snow White, <b>V:</b> Ivory White, <b>A:</b> Satin Silver, <b>U:</b> Urban Graphite, <b>B:</b> Jet Black, <b>X:</b> Satin Bronze, <b>K:</b> Satin Copper, <b>G:</b> Satin Gold
On Request	Radars Sensor, Emergency Module



**Microprismatic | Direct-Indirect**

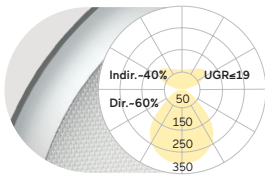

L mm	Lumen/Watt Medium Power	Lumen/Watt High Power
990	3760lm/31W	5070lm/40W
1290	5010lm/39W	6810lm/52W
1590	6480lm/49W	8450lm/65W

**Microprismatic | Direct**

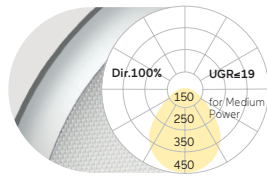

L mm	Lumen/Watt Medium Power	Lumen/Watt High Power
990	2280lm/19W	3150lm/27W
1290	3040lm/24W	4260lm/34W
1590	4020lm/32W	5260lm/42W

**Opal Diffuser | Direct-Indirect**

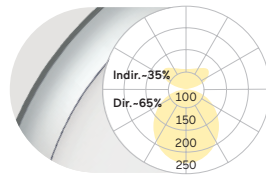

L mm	Lumen/Watt Medium Power	Lumen/Watt High Power
990	3860lm/31W	5210lm/40W
1290	5140lm/39W	6930lm/52W
1590	6610lm/49W	8660lm/65W

**Opal Diffuser | Direct**

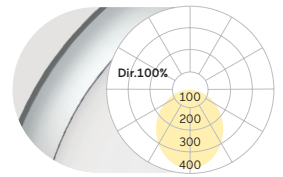

L mm	Lumen/Watt Medium Power	Lumen/Watt High Power
990	2380lm/19W	3290lm/27W
1290	3170lm/24W	4380lm/34W
1590	4150lm/32W	5470lm/42W

Lumen Values: Luminaire luminous flux at 4000K/CRI>80. Other configurations on request.

**Tube Suspension**

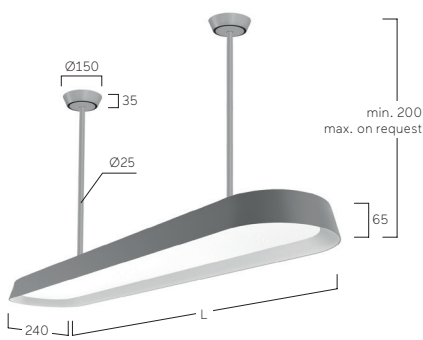

**Parallel Suspension**

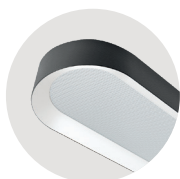

**B** Jet Black  
**W** Snow White

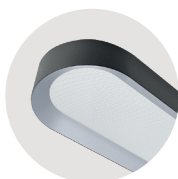

**B** Jet Black  
**S** Satin Silver

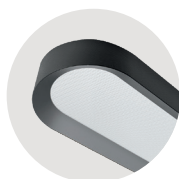

**B** Jet Black  
**U** Urban Graphite

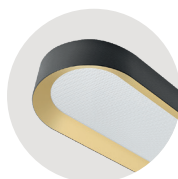

**B** Jet Black  
**G** Satin Gold

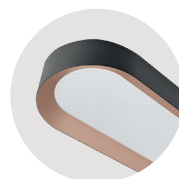

**B** Jet Black  
**K** Satin Copper

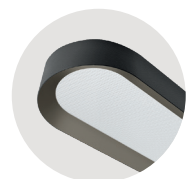

**B** Jet Black  
**X** Satin Bronze



## Beam Me Up (Soft Edge) A7 | Surface



**DE** LED-Anbauleuchte für Deckenmontage mit rückversetzter Optik und dekorativem Reflektoring. Direktstrahlend mit indirekter Lichtkorona oder rein direktstrahlend. Leuchtschirm aus hochwertig verarbeitetem Kunstguss. Gehäuse-Außenfläche und dekorativer Reflektoring in unterschiedlichen Lackierungen und Kombinationen erhältlich, z.B. weiß, silber, graphit, schwarz, gold oder kupferfarben lackiert. Zu Oberflächenoptionen- und Kombinationen siehe Lightnet-Surface-Collection oder Bi-Colour-Auswahl. Microprismenoptik mit optimierter Blendungsbegrenzung speziell für Office-Anwendungen. Satinierter Opaldiffusor für Allgemeinbeleuchtung mit max. Transmissionsgrad und homogener Lichtpunktauflösung. Konverter in Leuchtegehäuse integriert, wahlweise einfach schaltbar oder stufenlos dimmbar (DALI, Touch-Dim, Casambi). Farbtemperatur 2200K, 2700K, 3000K, 3500K, 4000K, 6500K oder Tunable White. Binning initial  $\leq$  MacAdam 3. Farbwiedergabe CRI $>$ 80, CRI $>$ 90 oder Full Spectrum.

**EN** LED surface-mounted luminaire for ceilings with a rebated lens optic in a decorative ring. Direct-indirect or direct-only light distribution. Luminaire shade made of high-quality processed synthetic cast. Outer housing and decorative reflector ring available in various finishes and combinations, e.g. white, silver, graphite, black, gold or copper coated. For surface options and combinations, see Lightnet-Surface-Collection or Bi-Colour selection. Microprismatic screen with optimized glare reduction for workplaces. Satin opal diffuser for general lighting with maximum transmittance and homogeneous lighting. Driver integrated into luminaire housing, available as switched or dimmable (DALI, Touch-Dim, Casambi). Colour temperature 2200K, 2700K, 3000K, 3500K, 4000K, 6500K or Tunable White. Binning  $\leq$  MacAdam 3. Colour rendering CRI $>$ 80, CRI $>$ 90 or Full Spectrum.

**M A7 A B L-8 30 M-Q440 - K**

- Product Family **M:** Beam Me Up
- Type **A7:** Direct only
- Optical System **A:** Microprismatic, **O:** Opal Diffuser
- Surface Finish **W:** Snow White, **V:** Ivory White, **A:** Satin Silver, **U:** Urban Graphite, **B:** Jet Black, **X:** Satin Bronze, **K:** Satin Copper
- Control Gear **E:** On/Off, **L:** DALI, **H:** Touch-Dim, **C:** Casambi, **6:** DALI DT6 for TW, **8:** DALI DT8 for TW
- Colour Rendering **8:** CRI>80, **9:** CRI>90, **F:** Full Spectrum [except 2200K]
- Colour Temperature **22:** 2200K, **27:** 2700K, **30:** 3000K, **35:** 3500K, **40:** 4000K, **65:** 6500K, **TW:** Tunable White 2700-6500K [Q640-Q840]
- Power **M:** Medium Power, **H:** High Power
- Size Luminaire Diameter in mm: **Q440, Q640, Q840**
- Reflector **W:** Snow White, **V:** Ivory White, **A:** Satin Silver, **U:** Urban Graphite, **B:** Jet Black, **X:** Satin Bronze, **K:** Satin Copper, **G:** Satin Gold
- On Request Radar Sensor, Emergency Module [Q640-Q840]

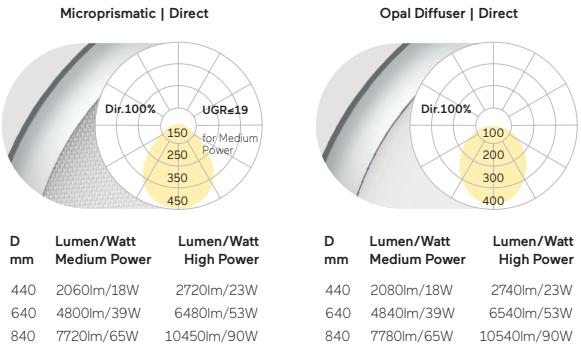

Lumen Values: Luminaire luminous flux at 4000K/CRI>80. Other configurations on request.

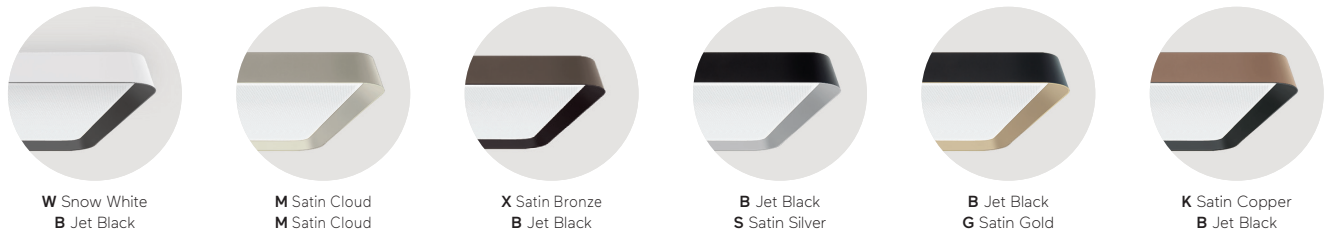
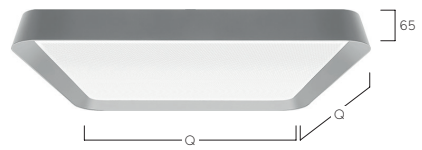

## Beam Me Up (Soft Edge) A8 | Surface



**DE** LED-Anbauleuchte für Wand- oder Deckenmontage mit rückversetzter Optik und dekorativem Reflektoring. Direktstrahlend mit indirekter Lichtkorona oder rein direktstrahlend. Leuchtschirm aus hochwertig verarbeitetem Kunstguss. Gehäuse-Außenfläche und dekorativer Reflektoring in unterschiedlichen Lackierungen und Kombinationen erhältlich, z.B. weiß, silber, graphit, schwarz, gold oder kupferfarben lackiert. Zu Oberflächenoptionen- und Kombinationen siehe Lightnet-Surface-Collection oder Bi-Colour-Auswahl. Microprismenoptik mit optimierter Blendungsbegrenzungsspeziell für Office-Anwendungen. Satinierter Opaldiffusor für Allgemeinbeleuchtung mit max. Transmissionsgrad und homogener Lichtpunktauflösung. Konverter in Leuchtegehäuse integriert, wahlweise einfach schaltbar oder stufenlos dimmbar (DALI, Touch-Dim, Casambi). Farbtemperatur 2200K, 2700K, 3000K, 3500K, 4000K, 6500K oder Tunable White. Binning initial  $\leq$  MacAdam 3. Farbwiedergabe CRI $>$ 80, CRI $>$ 90 oder Full Spectrum.

**EN** LED surface-mounted luminaire for walls and ceilings with a rebated lens optic in a decorative ring. Direct-indirect or direct-only light distribution. Luminaire shade made of high-quality processed synthetic cast. Outer housing and decorative reflector ring available in various finishes and combinations, e.g. white, silver, graphite, black, gold or copper coated. For surface options and combinations, see Lightnet-Surface-Collection or Bi-Colour selection. Microprismatic screen with optimized glare reduction for workplaces. Satin opal diffuser for general lighting with maximum transmittance and homogeneous lighting. Driver integrated into luminaire housing, available as switched or dimmable (DALI, Touch-Dim, Casambi). Colour temperature 2200K, 2700K, 3000K, 3500K, 4000K, 6500K or Tunable White. Binning  $\leq$  MacAdam 3. Colour rendering CRI $>$ 80, CRI $>$ 90 or Full Spectrum.

**M A8 O A L-8 30 M-L990 - G**

- Product Family **M:** Beam Me Up
- Type **A8:** Direct only
- Optical System **A:** Microprismatic, **O:** Opal Diffuser
- Surface Finish **W:** Snow White, **V:** Ivory White, **A:** Satin Silver, **U:** Urban Graphite, **B:** Jet Black, **X:** Satin Bronze, **K:** Satin Copper
- Control Gear **E:** On/Off, **L:** DALI, **H:** Touch-Dim, **C:** Casambi, **6:** DALI DT6 for TW, **8:** DALI DT8 for TW
- Colour Rendering **8:** CRI>80, **9:** CRI>90, **F:** Full Spectrum [except 2200K]
- Colour Temperature **22:** 2200K, **27:** 2700K, **30:** 3000K, **35:** 3500K, **40:** 4000K, **65:** 6500K, **TW:** Tunable White 2700-6500K
- Power **M:** Medium Power, **H:** High Power
- Size Luminaire Length in mm: **L990, L1290, L1590**
- Reflector **W:** Snow White, **V:** Ivory White, **A:** Satin Silver, **U:** Urban Graphite, **B:** Jet Black, **X:** Satin Bronze, **K:** Satin Copper, **G:** Satin Gold
- On Request Radar Sensor, Emergency Module



Microprismatic | Direct

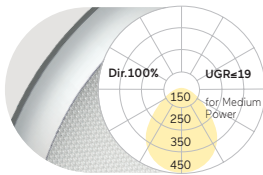

Opal Diffuser | Direct

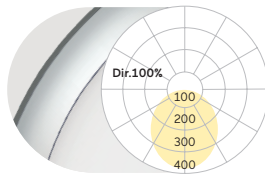

L mm	Lumen/Watt		L mm	Lumen/Watt	
	Medium Power	High Power		Medium Power	High Power
990	2280lm/19W	3150lm/27W	990	2380lm/19W	3290lm/27W
1290	3040lm/24W	4260lm/34W	1290	3170lm/24W	4380lm/34W
1590	4020lm/32W	5260lm/42W	1590	4150lm/32W	5470lm/42W

Lumen Values: Luminaire luminous flux at 4000K/CRI>80. Other configurations on request.

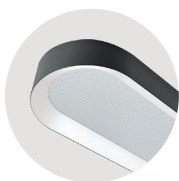
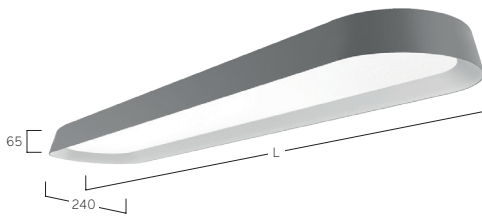

**B** Jet Black  
**W** Snow White

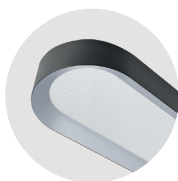

**B** Jet Black  
**S** Satin Silver

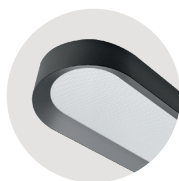

**B** Jet Black  
**U** Urban Graphite

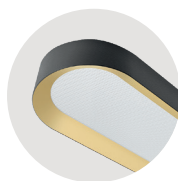

**B** Jet Black  
**G** Satin Gold

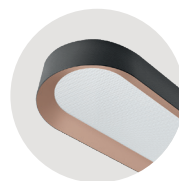

**B** Jet Black  
**K** Satin Copper

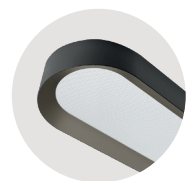

**B** Jet Black  
**X** Satin Bronze

## Caleo Evolution F2 | Floor

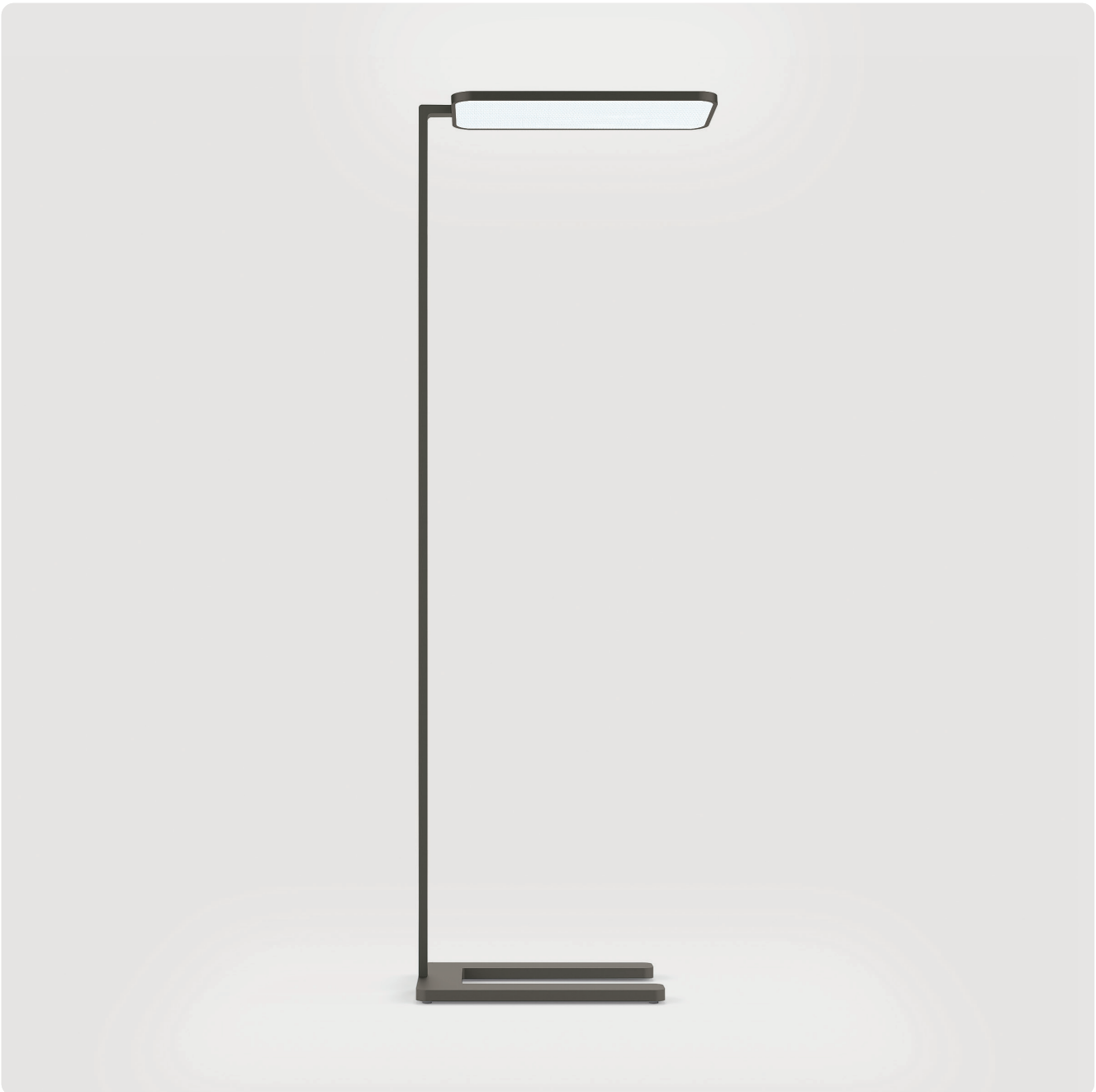

**DE** LED-Stehleuchte. Direkt-indirektstrahlend. Leuchtenkörper aus Aluminiumprofil. Oberfläche weiß, silber, graphit, schwarz, kupfer oder bronzefarben lackiert. Weitere Oberflächenoptionen siehe Lightnet-Surface-Collection oder RAL nach Wahl. Microprismenoptik mit optimierter Blendungsbegrenzung speziell für Office-Anwendungen bei vollständiger Lichtpunktauflösung. Intuitives Bedienfeld im Leuchtenmast für getrennt stufenlose Dimmung und Schaltung der Kammern für Direkt-/Indirektlicht. Farbtemperatur 2700K, 3000K, 3500K, 4000K oder 6500K. Binning initial  $\leq$  MacAdam 3. Farbwiedergabe CRI>80, CRI>90 oder Full Spectrum. Fußplatte aus Stahl, optional mit U- oder Side-Cut-Out für unterschiedliche Tischausführungen, Lackierung passend Leuchtenkörper. 4m Anschlusskabel mit länderspezifischem Stecker (EU, CH, UK).

**EN** LED free-standing luminaire. Direct-indirect light distribution. Luminaire body made of aluminium profile. Surface white, silver, graphite, black, copper or bronze coated. For further surface options see Lightnet-Surface-Collection or RAL of your choice. Microprismatic screen with optimized glare reduction for workplaces with uniform and enhanced light transmission. Intuitive control panel in luminaire pole for dimming and switching the direct/indirect light separately. Colour temperature 2700K, 3000K, 3500K, 4000K or 6500K. Binning  $\leq$  MacAdam 3. Colour rendering CRI>80, CRI>90 or Full Spectrum. Steel base plate, with U- or Side Cut-Out for different table designs, colour matching luminaire body. 4m power cable with country-specific plug (EU, CH, UK).

**A F2 A B X - 8 30 M - L600 - U - A**

Product Family	<b>A:</b> Caleo
Type	<b>F2:</b> Direct-Indirect
Optical System	<b>A:</b> Microprismatic, <b>O:</b> Opal
Surface Finish	<b>W:</b> Snow White, <b>V:</b> Ivory White, <b>S:</b> Radiant Silver, <b>U:</b> Urban Graphite, <b>B:</b> Jet Black, <b>X:</b> Satin Bronze, <b>K:</b> Satin Copper, <b>A:</b> Satin Silver
Control Gear	<b>X:</b> Separately Dimmable, <b>M:</b> Multisensor, <b>R:</b> Swarm Control, <b>B:</b> HCL, <b>C:</b> Casambi
Colour Rendering	<b>8:</b> CRI>80, <b>9:</b> CRI>90, <b>F:</b> Full Spectrum
Colour Temperature	<b>27:</b> 2700K, <b>30:</b> 3000K, <b>35:</b> 3500K, <b>40:</b> 4000K, <b>65:</b> 6500K, <b>TW:</b> Tunable White 2700-6500K
Power	<b>M:</b> Medium Power, <b>H:</b> High Power
Size	Head Length in mm: <b>L600</b>
Base*	<b>U:</b> U-Cut-Out, <b>I:</b> T-Shape
Plug	<b>A:</b> Schuko CEE 7/7 (Type E+F), <b>B:</b> CH T12 (Type J), <b>C:</b> UK BS 1363 (Type G), <b>D:</b> Wieland, <b>E:</b> WAGO

\*Bases with Soft Corners



**Microprismatic | Direct-Indirect**

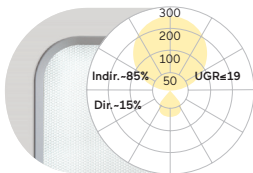

L mm	Lumen/Watt Medium Power	Lumen/Watt High Power
600	11100lm/68W	15300lm/92W

**Opal Diffuser | Direct-Indirect**

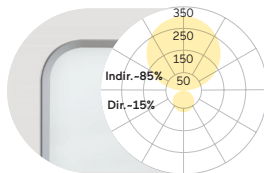

L mm	Lumen/Watt Medium Power	Lumen/Watt High Power
600	10800lm/68W	15000lm/92W

Lumen Values: Luminaire luminous flux at 4000K/CRI>80. Other configurations on request.



**U- Cut-Out Base**

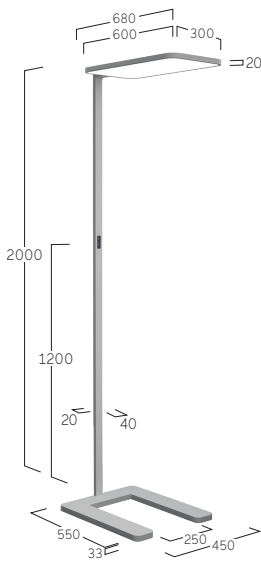

**T- Shape Base**



Multisensor/HCL /Swarm Control



Separately Dimmable



**W** Snow White



**S** Satin Silver



**B** Jet Black



**X** Satin Bronze



**G** Satin Gold



**K** Satin Copper

## Caleo Evolution F4 | Floor



**DE** LED-Stehleuchte. Direkt-indirektstrahlend. Leuchtenkörper aus Aluminiumprofil. Oberfläche weiß, silber, graphit, schwarz, kupfer oder bronzefarben lackiert. Weitere Oberflächenoptionen siehe Lightnet-Surface-Collection oder RAL nach Wahl. Microprismenoptik mit optimierter Blendungsbegrenzung speziell für Office-Anwendungen bei vollständiger Lichtpunktauflösung. Intuitives Bedienfeld im Leuchtenmast für getrennt stufenlose Dimmung und Schaltung der Kammern für Direkt-/Indirektlicht. Farbtemperatur 2700K, 3000K, 3500K, 4000K oder 6500K. Binning initial  $\leq$  MacAdam 3. Farbwiedergabe CRI>80, CRI>90 oder Full Spectrum. Fußplatte aus Stahl, Lackierung passend Leuchtenkörper. 4m Anschlusskabel mit länderspezifischem Stecker (EU, CH, UK).

**EN** LED free-standing luminaire. Direct-indirect light distribution. Luminaire body made of aluminium profile. Surface white, silver, graphite, black, copper or bronze coated. For further surface options see Lightnet-Surface-Collection or RAL of your choice. Microprismatic screen with optimized glare reduction for workplaces with uniform and enhanced light transmission. Intuitive control panel in luminaire pole for dimming and switching the direct/indirect light separately. Colour temperature 2700K, 3000K, 3500K, 4000K or 6500K. Binning  $\leq$  MacAdam 3. Colour rendering CRI>80, CRI>90 or Full Spectrum. Steel Base plate, colour matching luminaire body. 4m power cable with country-specific plug (EU, CH, UK).

**A F4 A B X - 8 30 M - Q600 - C - A**

Product Family	<b>A:</b> Caleo
Type	<b>F4:</b> Direct-Indirect
Optical System	<b>A:</b> Microprismatic, <b>O:</b> Opal
Surface Finish	<b>W:</b> Snow White, <b>V:</b> Ivory White, <b>S:</b> Radiant Silver, <b>U:</b> Urban Graphite, <b>B:</b> Jet Black, <b>X:</b> Satin Bronze, <b>K:</b> Satin Copper, <b>A:</b> Satin Silver
Control Gear	<b>X:</b> Separately Dimmable, <b>C:</b> Casambi, <b>M:</b> Multisensor, <b>R:</b> Swarm Control, <b>B:</b> HCL
Colour Rendering	<b>8:</b> CRI>80, <b>9:</b> CRI>90, <b>F:</b> Full Spectrum
Colour Temperature	<b>27:</b> 2700K, <b>30:</b> 3000K, <b>35:</b> 3500K, <b>40:</b> 4000K, <b>65:</b> 6500K, <b>TW:</b> Tunable White 2700-6500K
Power	<b>M:</b> Medium Power
Size	Head Size in mm: <b>Q600</b>
Base	<b>C:</b> Square*, <b>X:</b> X-Shape*
Plug	<b>A:</b> Schuko CEE 7/7 (Type E+F), <b>B:</b> CH T12 (Type J), <b>C:</b> UK BS 1363 (Type G), <b>D:</b> Wieland, <b>E:</b> WAGO

\*Bases with Soft Corners



**Microprismatic | Direct-Indirect**

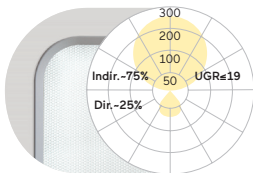

**Q** Lumen/Watt  
mm Medium Power  
640 17600lm/115W

**Opal Diffuser | Direct-Indirect**

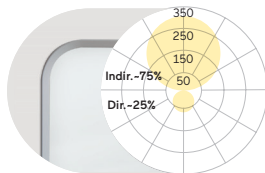

**Q** Lumen/Watt  
mm Medium Power  
640 17400lm/115W

Lumen Values: Luminaire luminous flux at 4000K/CRI>80. Other configurations on request.

**X-Shape Base**

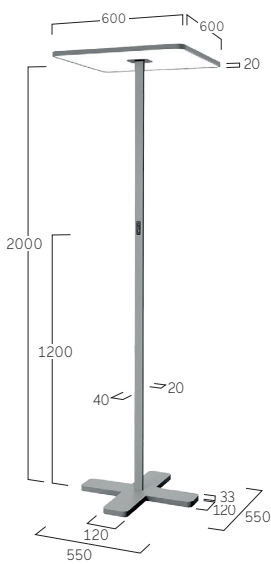

**Square Base**

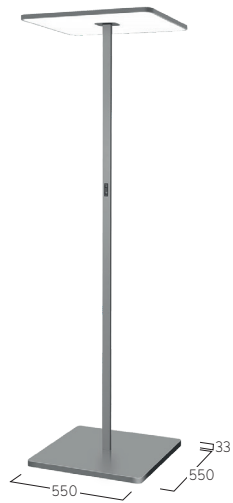

Multisensor/HCL/Swarm Control



Separately Dimmable



**W** Snow White



**S** Satin Silver



**B** Jet Black



**X** Satin Bronze



**G** Satin Gold



**K** Satin Copper



## Caleo Evolution Y7/X7 | Wall



**DE** LED-Anbauleuchte für Wand- und Deckenmontage. Direktstrahlend mit indirekter Lichtkorona oder rein direktstrahlend. Leuchtenkörper aus Aluminiumprofil. Oberfläche weiß, silber, graphit, schwarz, kupfer oder bronzefarben lackiert. Weitere Oberflächenoptionen siehe Lightnet-Surface-Collection oder RAL nach Wahl. Microprismenoptik mit optimierter Blendungsbegrenzung speziell für Office-Anwendungen. Satinierter Opaldiffusor für Allgemeinbeleuchtung mit max. Transmissionsgrad und homogener Lichtpunktauflösung. Konverter in Leuchtengehäuse integriert, wahlweise einfach schaltbar oder stufenlos dimmbar (DALI, Touch-Dim, Casambi). Farbtemperatur 2200K, 2700K, 3000K, 3500K, 4000K, 6500K oder Tunable White (2700-6500K). Binning initial  $\leq$  MacAdam 3. Farbwiedergabe CRI $>$ 80, CRI $>$ 90 oder Full Spectrum. Auf Anfrage: Integration von Notlichtkomponenten.

**EN** LED surface-mounted luminaire for walls and ceilings. Direct light distribution and indirect lighting corona or direct only light distribution. Luminaire body made of aluminium profile. Surface white, silver, graphite, black, copper or bronze coated. For further surface options see Lightnet-Surface-Collection or RAL of your choice. Microprismatic screen with optimized glare reduction for workplaces. Satin opal diffuser for general lighting with maximum transmittance and homogeneous lighting. Driver integrated into luminaire housing, available as switched or dimmable (DALI, Touch-Dim, Casambi). Colour temperature 2200K, 2700K, 3000K, 3500K, 4000K, 6500K or Tunable White (2700-6500K). Binning  $\leq$  MacAdam 3. Colour rendering CRI $>$ 80, CRI $>$ 90 or Full Spectrum. On request: Integration of emergency lighting components.

**AX7 AWE-8 30 M-Q300**

Product Family	<b>A:</b> Caleo
Type	<b>X7:</b> Direct-Indirect, <b>Y7:</b> Direct Only
Optical System	<b>A:</b> Microprismatic, <b>O:</b> Opal Diffuser
Surface Finish	<b>W:</b> Snow White, <b>V:</b> Ivory White, <b>S:</b> Radiant Silver, <b>U:</b> Urban Graphite, <b>B:</b> Jet Black, <b>X:</b> Satin Bronze, <b>K:</b> Satin Copper
Control Gear	<b>E:</b> On/Off, <b>L:</b> DALI, <b>H:</b> Touch-Dim, <b>C:</b> Casambi, <b>6:</b> DALI DT6 for TW, <b>8:</b> DALI DT8 for TW
Colour Rendering	<b>8:</b> CRI>80, <b>9:</b> CRI>90, <b>F:</b> Full Spectrum [except 2200K]
Colour Temperature	<b>22:</b> 2200K, <b>27:</b> 2700K, <b>30:</b> 3000K, <b>35:</b> 3500K, <b>40:</b> 4000K, <b>65:</b> 6500K, <b>TW:</b> Tunable White (Q400-Q800)
Power	<b>M:</b> Medium Power, <b>H:</b> High Power
Size	Square Size in mm: <b>Q300, Q400, Q500, Q600, Q800</b>



**Microprismatic | Direct-Indirect**

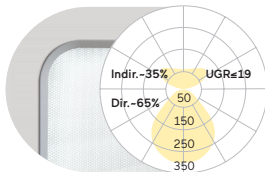

**Microprismatic | Direct**

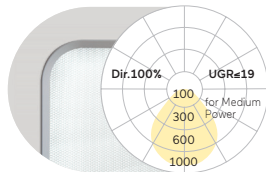

**Opal Diffuser | Direct-Indirect**

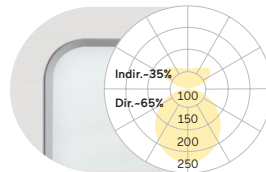

**Opal Diffuser | Direct**

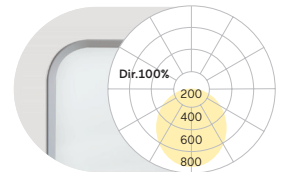

Q mm	Lumen/Watt Medium Power	Lumen/Watt High Power
300	1990lm/17W	2700lm/22W
400	2930lm/23W	3890lm/31W
500	5140lm/39W	6720lm/52W
600	6790lm/54W	9230lm/73W
800	10780lm/86W	14900lm/121W

Q mm	Lumen/Watt Medium Power	Lumen/Watt High Power
300	1230lm/11W	1670lm/15W
400	2060lm/18W	2720lm/23W
500	3180lm/26W	4180lm/35W
600	4800lm/39W	6480lm/53W
800	7720lm/65W	10450lm/90W

Q mm	Lumen/Watt Medium Power	Lumen/Watt High Power
300	2000lm/17W	2720lm/22W
400	2950lm/23W	3910lm/31W
500	5170lm/39W	6760lm/52W
600	6830lm/54W	9290lm/73W
800	10840lm/86W	14990lm/121W

Q mm	Lumen/Watt Medium Power	Lumen/Watt High Power
300	1240lm/11W	1690lm/15W
400	2080lm/18W	2740lm/23W
500	3210lm/26W	4220lm/35W
600	4840lm/39W	6540lm/53W
800	7780lm/65W	10540lm/90W

Lumen Values: Luminaire luminous flux at 4000K/CRI>80. Other configurations on request.

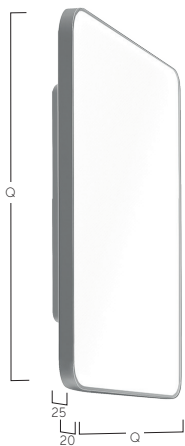

**W** Snow White



**S** Satin Silver



**B** Jet Black



**X** Satin Bronze



**G** Satin Gold



**K** Satin Copper

## Caleo Evolution G8/P8 | Suspended



**DE** LED-Pendelleuchte. Direkt-indirekt oder rein direktstrahlend. Leuchtenkörper aus Aluminiumprofil. Oberfläche weiß, silber, graphit, schwarz, kupfer oder bronzefarben lackiert. Weitere Oberflächenoptionen siehe Lightnet-Surface-Collection oder RAL nach Wahl. Microprismenoptik mit optimierter Blendungsbegrenzung speziell für Office-Anwendungen. Satinierter Opaldiffusor für Allgemeinbeleuchtung mit max. Transmissionsgrad und homogener Lichtpunktauflösung. Konverter in Leuchtengehäuse integriert, wahlweise einfach schaltbar oder stufenlos dimmbar (DALI, Touch-Dim, Casambi). Farbtemperatur 2200K, 2700K, 3000K, 3500K, 4000K oder 6500K. Binning initial  $\leq$  MacAdam 3. Farbwiedergabe CRI $>$ 80, CRI $>$ 90 oder Full Spectrum. Stufenlos höhenverstellbare Parallel- oder Y-Seilabhängung mit transparent ummantelter Zuleitung oder Pendelrohrabhängung. Lackierung Baldachin passend Leuchtenkörper. Auf Anfrage: Integration von Notlichtkomponenten.

**EN** LED pendant luminaire. Direct-indirect or direct-only light distribution. Luminaire body made of aluminium profile. Surface white, silver, graphite, black, copper or bronze coated. For further surface options see Lightnet-Surface-Collection or RAL of your choice. Microprismatic screen with optimized glare reduction. Satin opal diffuser for general lighting with maximum transmittance and uniformity. Driver integrated into luminaire housing, available as switched or dimmable (DALI, Touch-Dim, Casambi). Colour temperature 2200K, 2700K, 3000K, 3500K, 4000K or 6500K. Binning  $\leq$  MacAdam 3. Colour rendering CRI $>$ 80, CRI $>$ 90 or Full Spectrum. Height-adjustable parallel or Y-cord suspension with transparent power supply cable or rod suspension. Ceiling rose colour to match luminaire body. On request: Integration of emergency lighting components.

**A P8 A WE-8 30 M-L900-K**

Product Family	<b>A:</b> Caleo
Type	<b>G8:</b> Direct only, <b>P8:</b> Direct-Indirect
Optical System	<b>A:</b> Microprismatic, <b>O:</b> Opal Diffuser
Surface Finish	<b>W:</b> Snow White, <b>V:</b> Ivory White, <b>S:</b> Radiant Silver, <b>U:</b> Urban Graphite, <b>B:</b> Jet Black, <b>X:</b> Satin Bronze, <b>K:</b> Satin Copper
Control Gear	<b>E:</b> On/Off, <b>L:</b> DALI, <b>H:</b> Touch-Dim, <b>M:</b> Multisensor, <b>C:</b> Casambi, <b>6:</b> DALI DT6 for TW, <b>8:</b> DALI DT8 for TW
Colour Rendering	<b>8:</b> CRI>80, <b>9:</b> CRI>90, <b>F:</b> Full Spectrum [except 2200K]
Colour Temperature	<b>22:</b> 2200K, <b>27:</b> 2700K, <b>30:</b> 3000K, <b>35:</b> 3500K, <b>40:</b> 4000K, <b>65:</b> 6500K, <b>TW:</b> Tunable White
Power	<b>M:</b> Medium Power, <b>H:</b> High Power
Size	Luminaire Length in mm: <b>L900, L1200, L1500</b>
Suspension	<b>K:</b> Parallel Suspension, <b>Y:</b> Y-Cord Suspension, <b>P:</b> Tube Suspension



**Microprismatic | Direct-Indirect**

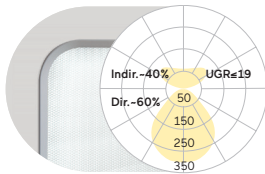

L mm	Lumen/Watt Medium Power	Lumen/Watt High Power
900	3760lm/31W	5070lm/40W
1200	5010lm/39W	6810lm/52W
1500	6480lm/49W	8450lm/65W

**Microprismatic | Direct**

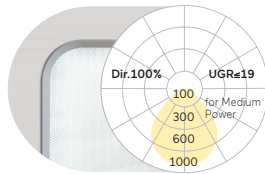

L mm	Lumen/Watt Medium Power	Lumen/Watt High Power
900	2280lm/19W	3150lm/27W
1200	3040lm/24W	4260lm/34W
1500	4020lm/32W	5260lm/42W

**Opal Diffuser | Direct-Indirect**

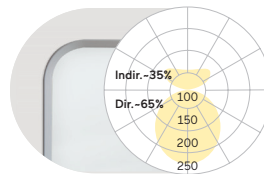

L mm	Lumen/Watt Medium Power	Lumen/Watt High Power
900	3860lm/31W	5210lm/40W
1200	5140lm/39W	6930lm/52W
1500	6610lm/49W	8660lm/65W

**Opal Diffuser | Direct**

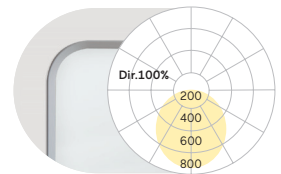

L mm	Lumen/Watt Medium Power	Lumen/Watt High Power
900	2380lm/19W	3290lm/27W
1200	3170lm/24W	4380lm/34W
1500	4150lm/32W	5470lm/42W

Lumen Values: Luminaire luminous flux at 4000K/CRI>80. Other configurations on request.

**Parallel Suspension**

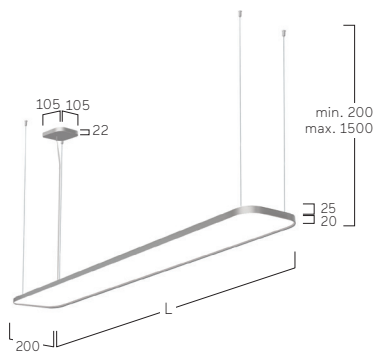

**Y-Cord Suspension**



**Tube Suspension**

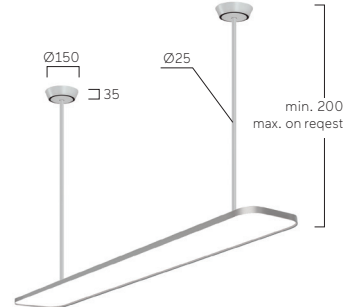

**W** Snow White



**S** Satin Silver



**B** Jet Black



**X** Satin Bronze



**G** Satin Gold



**K** Satin Copper

## Caleo Evolution G7/P7 | Suspended



**DE** LED-Pendelleuchte. Direkt-indirekt oder rein direktstrahlend. Leuchtenkörper aus Aluminiumprofil. Oberfläche weiß, silber, graphit, schwarz, kupfer oder bronzefarben lackiert. Weitere Oberflächenoptionen siehe Lightnet-Surface-Collection oder RAL nach Wahl. Microprismenoptik mit optimierter Blendungsbegrenzung speziell für Office-Anwendungen. Satinierter Opaldiffusor für Allgemeinbeleuchtung mit max. Transmissionsgrad und homogener Lichtpunktauflösung. Konverter in Leuchtengehäuse integriert, wahlweise einfach schaltbar oder stufenlos dimmbar (DALI, Touch-Dim, Casambi). Farbtemperatur 2200K, 2700K, 3000K, 3500K, 4000K oder 6500K. Binning initial  $\leq$  MacAdam 3. Farbwiedergabe CRI $>$ 80, CRI $>$ 90 oder Full Spectrum. Stufenlos höhenverstellbare Parallelseil-Abhängung mit transparent ummantelter Zuleitung oder Pendelrohrabhängung. Lackierung Baldachin passend Leuchtenkörper. Auf Anfrage: Integration von Notlichtkomponenten.

**EN** LED pendant luminaire. Direct-indirect or direct-only light distribution. Luminaire body made of aluminium profile. Surface white, silver, graphite, black, copper or bronze coated. For further surface options see Lightnet-Surface-Collection or RAL of your choice. Microprismatic screen with optimized glare reduction for workplaces. Satin opal diffuser for general lighting with maximum transmittance and homogeneous lighting. Driver integrated into luminaire housing, available as switched or dimmable (DALI, Touch-Dim, Casambi). Colour temperature 2200K, 2700K, 3000K, 3500K, 4000K or 6500K. Binning  $\leq$  MacAdam 3. Colour rendering CRI $>$ 80, CRI $>$ 90 or Full Spectrum. Height-adjustable parallel cord suspension with transparent power supply cable or rod suspension. Ceiling rose colour to match luminaire body. On request: Integration of emergency lighting components.

**AP7 AWE-8 30 M-Q300-K**

Product Family	<b>A:</b> Caleo
Type	<b>G7:</b> Direct only, <b>P7:</b> Direct-Indirect
Optical System	<b>A:</b> Microprismatic, <b>O:</b> Opal Diffuser
Surface Finish	<b>W:</b> Snow White, <b>V:</b> Ivory White, <b>S:</b> Radiant Silver, <b>U:</b> Urban Graphite, <b>B:</b> Jet Black, <b>X:</b> Satin Bronze, <b>K:</b> Satin Copper
Control Gear	<b>E:</b> On/Off, <b>L:</b> DALI, <b>H:</b> Touch-Dim, <b>C:</b> Casambi, <b>6:</b> DALI DT6 for TW, <b>8:</b> DALI DT8 for TW
Colour Rendering	<b>8:</b> CRI>80, <b>9:</b> CRI>90, <b>F:</b> Full Spectrum [except 2200K]
Colour Temperature	<b>22:</b> 2200K, <b>27:</b> 2700K, <b>30:</b> 3000K, <b>35:</b> 3500K, <b>40:</b> 4000K, <b>65:</b> 6500K, <b>TW:</b> Tunable White (Q400 - Q800)
Power	<b>M:</b> Medium Power, <b>H:</b> High Power
Size	Square Size in mm: <b>Q300, Q400, Q500, Q600, Q800</b>
Suspension	<b>K:</b> Parallel Suspension, <b>P:</b> Tube Suspension (Q400 - Q800)



**Microprismatic | Direct-Indirect**

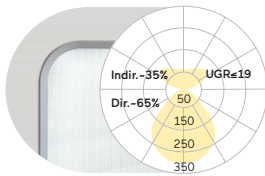

Q mm	Lumen/Watt Medium Power	Lumen/Watt High Power
300	1990lm/17W	2700lm/22W
400	2930lm/23W	3890lm/31W
500	5140lm/39W	6720lm/52W
600	6790lm/54W	9230lm/73W
800	10780lm/86W	14900lm/121W

**Microprismatic | Direct**

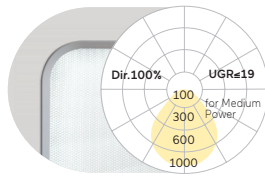

Q mm	Lumen/Watt Medium Power	Lumen/Watt High Power
300	1230lm/11W	1670lm/15W
400	2060lm/18W	2720lm/23W
500	3180lm/26W	4180lm/35W
600	4800lm/39W	6480lm/53W
800	7720lm/65W	10450lm/90W

**Opal Diffuser | Direct-Indirect**

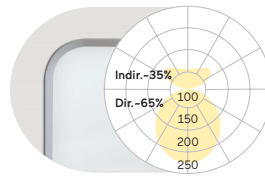

Q mm	Lumen/Watt Medium Power	Lumen/Watt High Power
300	2000lm/17W	2720lm/22W
400	2950lm/23W	3910lm/31W
500	5170lm/39W	6760lm/52W
600	6830lm/54W	9290lm/73W
800	10840lm/86W	14990lm/121W

**Opal Diffuser | Direct**

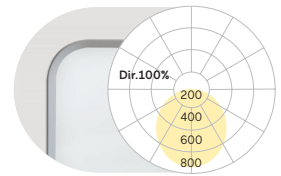

Q mm	Lumen/Watt Medium Power	Lumen/Watt High Power
300	1240lm/11W	1690lm/15W
400	2080lm/18W	2740lm/23W
500	3210lm/26W	4220lm/35W
600	4840lm/39W	6540lm/53W
800	7780lm/65W	10540lm/90W

Lumen Values: Luminaire luminous flux at 4000K/CRI>80. Other configurations on request.

**Parallel Suspension**

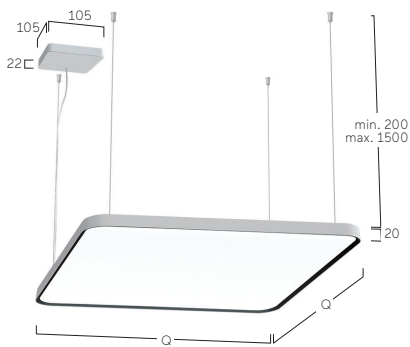

**Tube Suspension**

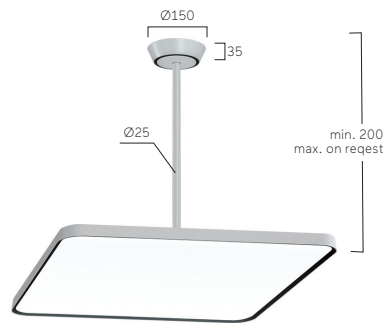

**W** Snow White



**S** Satin Silver



**B** Jet Black



**X** Satin Bronze



**G** Satin Gold



**K** Satin Copper

## Caleo Evolution Y8/X8 | Surface



**DE** LED-Pendelleuchte. Direktstrahlend mit indirekter Lichtkorona oder rein direktstrahlend. Leuchtenkörper aus Aluminiumprofil. Oberfläche weiß, silber, graphit, schwarz, kupfer oder bronzefarben lackiert. Weitere Oberflächenoptionen siehe Lightnet-Surface-Collection oder RAL nach Wahl. Microprismenoptik mit optimierter Blendungsbegrenzung speziell für Office-Anwendungen. Satinierter Opaldiffusor für Allgemeinbeleuchtung mit max. Transmissionsgrad und homogener Lichtpunktauflösung. Konverter in Leuchtengehäuse integriert, wahlweise einfach schaltbar oder stufenlos dimmbar (DALI, Touch-Dim, Casambi). Farbtemperatur 2200K, 2700K, 3000K, 3500K, 4000K oder 6500K. Binning initial  $\leq$  MacAdam 3. Farbwiedergabe CRI>80, CRI>90 oder Full Spectrum.

**EN** LED pendant luminaire. Direct light distribution and indirect lighting corona or direct only light distribution. Luminaire body made of aluminium profile. Surface white, silver, graphite, black, copper or bronze coated. For further surface options see Lightnet-Surface-Collection or RAL of your choice. Microprismatic screen with optimized glare reduction for workplaces. Satin opal diffuser for general lighting with maximum transmittance and uniformity. Driver integrated into luminaire housing, available as switched or dimmable (DALI, Touch-Dim, Casambi). Colour temperature 2200K, 2700K, 3000K, 3500K, 4000K or 6500K. Binning  $\leq$  MacAdam 3. Colour rendering CRI>80, CRI>90 or Full Spectrum.

**A X8 A WE-8 30 M-L900**

Product Family	<b>A:</b> Caleo
Type	<b>X8:</b> Direct-Indirect, <b>Y8:</b> Direct only
Optical System	<b>A:</b> Microprismatic, <b>O:</b> Opal Diffuser
Surface Finish	<b>W:</b> Snow White, <b>V:</b> Ivory White, <b>S:</b> Radiant Silver, <b>U:</b> Urban Graphite, <b>B:</b> Jet Black, <b>X:</b> Satin Bronze, <b>K:</b> Satin Copper
Control Gear	<b>E:</b> On/Off, <b>L:</b> DALI, <b>H:</b> Touch-Dim, <b>C:</b> Casambi, <b>6:</b> DALI DT6 for TW, <b>8:</b> DALI DT8 for TW
Colour Rendering	<b>8:</b> CRI>80, <b>9:</b> CRI>90, <b>F:</b> Full Spectrum [except 2200K]
Colour Temperature	<b>22:</b> 2200K, <b>27:</b> 2700K, <b>30:</b> 3000K, <b>35:</b> 3500K, <b>40:</b> 4000K, <b>65:</b> 6500K, <b>TW:</b> Tunable White
Power	<b>M:</b> Medium Power, <b>H:</b> High Power
Size	Luminaire Length in mm: <b>L900, L1200, L1500</b>



**Microprismatic | Direct-Indirect**

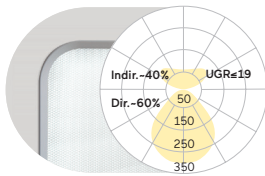

L mm	Lumen/Watt Medium Power	Lumen/Watt High Power
900	3760lm/31W	5070lm/40W
1200	5010lm/39W	6810lm/52W
1500	6480lm/49W	8450lm/65W

**Microprismatic | Direct**

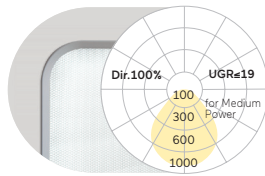

L mm	Lumen/Watt Medium Power	Lumen/Watt High Power
900	2280lm/19W	3150lm/27W
1200	3040lm/24W	4260lm/34W
1500	4020lm/32W	5260lm/42W

**Opal Diffuser | Direct-Indirect**

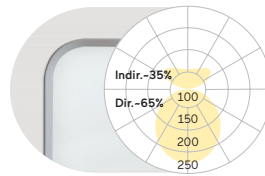

L mm	Lumen/Watt Medium Power	Lumen/Watt High Power
900	3860lm/31W	5210lm/40W
1200	5140lm/39W	6930lm/52W
1500	6610lm/49W	8660lm/65W

**Opal Diffuser | Direct**

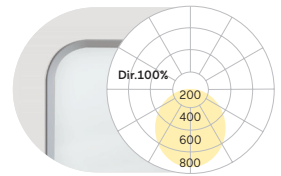

L mm	Lumen/Watt Medium Power	Lumen/Watt High Power
900	2380lm/19W	3290lm/27W
1200	3170lm/24W	4380lm/34W
1500	4150lm/32W	5470lm/42W

Lumen Values: Luminaire luminous flux at 4000K/CRI>80. Other configurations on request.

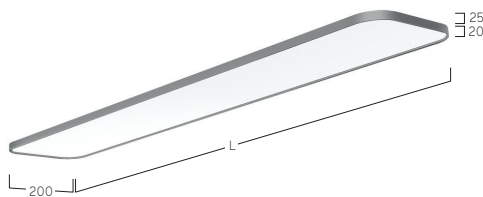

**W** Snow White



**S** Satin Silver



**B** Jet Black



**X** Satin Bronze



**G** Satin Gold



**K** Satin Copper



## Caleo Evolution Y7/X7 | Surface

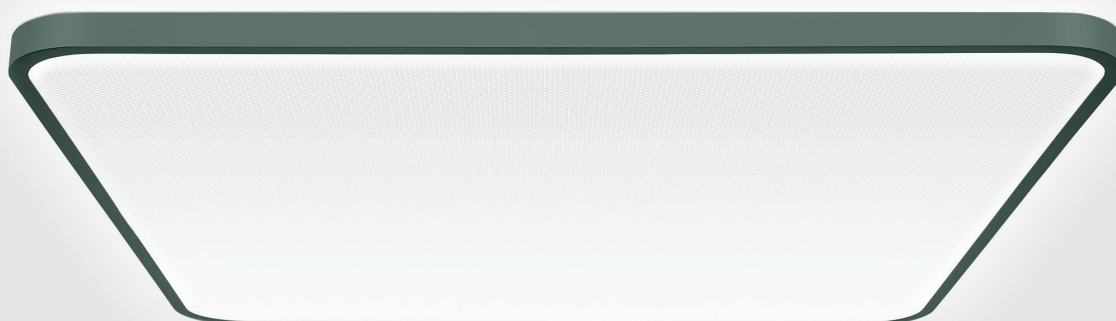

**DE** LED-Anbauleuchte für Wand- und Deckenmontage. Direktstrahlend mit indirekter Lichtkorona oder rein direktstrahlend. Leuchtenkörper aus Aluminiumprofil. Oberfläche weiß, silber, graphit, schwarz, kupfer oder bronzefarben lackiert. Weitere Oberflächenoptionen siehe Lightnet-Surface-Collection oder RAL nach Wahl. Microprismenoptik mit optimierter Blendungsbegrenzung speziell für Office-Anwendungen. Satinierter Opal-diffusor für Allgemeinbeleuchtung mit max. Transmissionsgrad und homogener Lichtpunktauflösung. Konverter in Leuchtgehäuse integriert, wahlweise einfach schaltbar oder stufenlos dimmbar (DALI, Touch-Dim, Casambi). Farbtemperatur 2200K, 2700K, 3000K, 3500K, 4000K, 6500K oder Tunable White (2700-6500K). Binning initial  $\leq$  MacAdam 3. Farbwiedergabe CRI $>$ 80, CRI $>$ 90 oder Full Spectrum. Auf Anfrage: Integration von Notlichtkomponenten.

**EN** LED surface-mounted luminaire for walls and ceilings. Direct light distribution and indirect lighting corona or direct only light distribution. Luminaire body made of aluminium profile. Surface white, silver, graphite, black, copper or bronze coated. For further surface options see Lightnet-Surface-Collection or RAL of your choice. Microprismatic screen with optimized glare reduction Satin opal diffuser for general lighting with maximum transmittance and uniformity. Driver integrated into luminaire housing, available as switched or dimmable (DALI, Touch-Dim, Casambi). Colour temperature 2200K, 2700K, 3000K, 3500K, 4000K, 6500K or Tunable White (2700-6500K). Binning  $\leq$  MacAdam 3. Colour rendering CRI $>$ 80, CRI $>$ 90 or Full Spectrum. On request: Integration of emergency lighting components.

**A X7 A W E - 8 30 M - Q300**

Product Family	<b>A:</b> Caleo
Type	<b>X7:</b> Direct-Indirect, <b>Y7:</b> Direct Only
Optical System	<b>A:</b> Microprismatic, <b>O:</b> Opal Diffuser
Surface Finish	<b>W:</b> Snow White, <b>V:</b> Ivory White, <b>S:</b> Radiant Silver, <b>U:</b> Urban Graphite, <b>B:</b> Jet Black, <b>X:</b> Satin Bronze, <b>K:</b> Satin Copper
Control Gear	<b>E:</b> On/Off, <b>L:</b> DALI, <b>H:</b> Touch-Dim, <b>C:</b> Casambi, <b>6:</b> DALI DT6 for TW, <b>8:</b> DALI DT8 for TW
Colour Rendering	<b>8:</b> CRI>80, <b>9:</b> CRI>90, <b>F:</b> Full Spectrum [except 2200K]
Colour Temperature	<b>22:</b> 2200K, <b>27:</b> 2700K, <b>30:</b> 3000K, <b>35:</b> 3500K, <b>40:</b> 4000K, <b>65:</b> 6500K, <b>TW:</b> Tunable White (Q400-Q800)
Power	<b>M:</b> Medium Power, <b>H:</b> High Power
Size	Square Size in mm: <b>Q300, Q400, Q500, Q600, Q800</b>



**Microprismatic | Direct-Indirect**

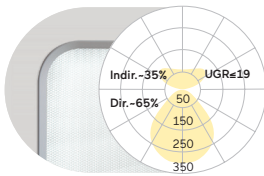

Q mm	Lumen/Watt Medium Power	Lumen/Watt High Power
300	1990lm/17W	2700lm/22W
400	2930lm/23W	3890lm/31W
500	5140lm/39W	6720lm/52W
600	6790lm/54W	9230lm/73W
800	10780lm/86W	14900lm/121W

**Microprismatic | Direct**

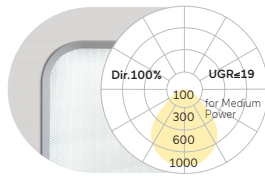

Q mm	Lumen/Watt Medium Power	Lumen/Watt High Power
300	1230lm/11W	1670lm/15W
400	2060lm/18W	2720lm/23W
500	3180lm/26W	4180lm/35W
600	4800lm/39W	6480lm/53W
800	7720lm/65W	10450lm/90W

**Opal Diffuser | Direct-Indirect**

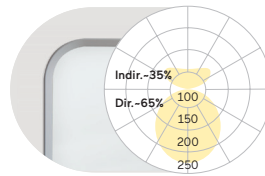

Q mm	Lumen/Watt Medium Power	Lumen/Watt High Power
300	2000lm/17W	2720lm/22W
400	2950lm/23W	3910lm/31W
500	5170lm/39W	6760lm/52W
600	6830lm/54W	9290lm/73W
800	10840lm/86W	14990lm/121W

**Opal Diffuser | Direct**

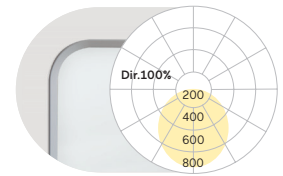

Q mm	Lumen/Watt Medium Power	Lumen/Watt High Power
300	1240lm/11W	1690lm/15W
400	2080lm/18W	2740lm/23W
500	3210lm/26W	4220lm/35W
600	4840lm/39W	6540lm/53W
800	7780lm/65W	10540lm/90W

Lumen Values: Luminaire luminous flux at 4000K/CRI>80. Other configurations on request.

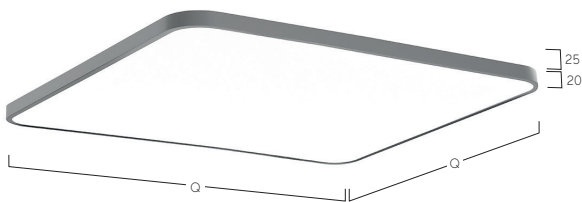

**W** Snow White



**S** Satin Silver



**B** Jet Black



**X** Satin Bronze



**G** Satin Gold

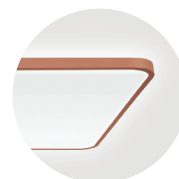

**K** Satin Copper

# Matric GQ | System 25mm Suspended



**DE** LED-Pendelleuchte. Direkt-indirekt oder rein direktstrahlend. Lichtkanal aus Aluminiumprofil mit 25mm Optikbreite. Millimetergenaue Längenfertigung nach Vorgabe möglich. Oberfläche natureloxiert oder weiß, graphit, schwarz, bronze- oder kupferfarben lackiert. Weitere Oberflächenoptionen siehe Lightnet-Surface-Collection oder RAL nach Wahl. Direktanteil über Präzisionslinsen mit Abblenderaster für breite rotationssymmetrische Lichtstärkeverteilung bei gleichzeitig hoher Blendungsbegrenzung (UGR<19) für Office Anwendungen. Abblenderaster in verschiedenen Farbkombinationen erhältlich. Satinierter Opaldiffusor für Allgemeinbeleuchtung mit max. Transmissionsgrad und homogener Lichtpunktauflösung. Wallwasher für homogene Beleuchtung vertikaler Flächen. Konverter in Leuchtgehäuse integriert, wahlweise einfach schaltbar oder stufenlos dimmbar (DALI, Touch-Dim, Casambi). Farbtemperatur 2200K, 2700K, 3000K, 3500K, 4000K, 6500K oder Tunable White (2700-6500K). Binning initial  $\leq$  MacAdam 3. Farbwiedergabe CRI>80, CRI>90 oder Full Spectrum. Stufenlos höhenverstellbare Seilabhängung mit transparent ummantelter Zuleitung. Lackierung Baldachin passend Leuchtenkörper. Auf Anfrage: Integration von Stromschienen und Strahlern, Sensortechnologie.

**EN** LED pendant luminaire. Direct-indirect or direct-only light distribution. Light channel made of aluminium profile with 25mm optic width. Bespoke lengths are possible. Surface natural anodised or white, graphite, black, bronze or copper coated. For further surface options see Lightnet-Surface-Collection or RAL of your choice. Direct light using precision lenses with louvre for wide uniform symmetrical light distribution with high glare limitation (UGR<19) for workplaces. Louvre available in various colour finishes. Satin opal diffuser for general lighting with maximum transmittance and homogeneous lighting. Wallwasher for homogeneous illumination of vertical surfaces. Driver integrated into luminaire housing, available as switched or dimmable (DALI, Touch-Dim, Casambi). Colour temperature 2200K, 2700K, 3000K, 3500K, 4000K, 6500K or Tunable White (2700-6500K). Binning  $\leq$  MacAdam 3. Colour rendering CRI>80, CRI>90 or Full Spectrum. Height-adjustable cord suspension with transparent power supply cable. Colours ceiling rose match to luminaire body. On request: Integration of tracks and spotlights, sensor technology.

**LGQLWE-8 30E-L1475-AD**

Product Family	L: Matric
Type	GQ: Direct only
Optical System	O: Opal Diffuser, G: Wallwasher, L: Lens Louvre*
Surface Finish	W: Snow White, Y: Black Anodised, V: Ivory White, F: Anodic Silver, M: Satin Cloud, X: Satin Bronze
Control Gear	E: On/Off, L: DALI, C: Casambi, 6: DALI DT6 for TW, 8: DALI DT8 for TW
Colour Rendering	8: CRI>80, 9: CRI>90, F: Full Spectrum [except 2200K]
Colour Temperature	22: 2200K, 27: 2700K, 30: 3000K, 35: 3500K, 40: 4000K, 65: 6500K, TW: Tunable White 2700-6500K
Power	E: Low Power, M: Medium Power, H: High Power
Size	Luminaire Length in mm (Opal Diffuser, Wallwasher): <b>L890, L1182, L1475, L1765, L2055</b> Luminaire Length in mm (Lens Louvre*): <b>L906, L1267, L1628, L1990</b>
Suspension	A: Single Cord Suspension
Louvre Surface	W: Snow White, D: Anodic Black, F: Anodic Silver, V: Ivory White, M: Satin Cloud, K: Satin Copper, G: Satin Gold, J: Satin Pale Gold, L: Satin Cupria

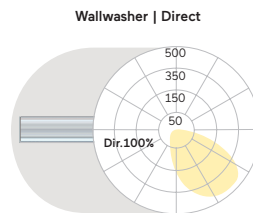
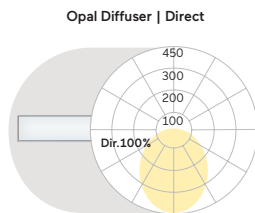
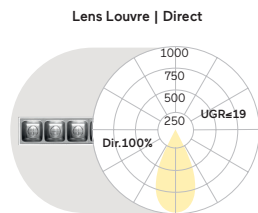

L mm	Lumen/Watt Low Power	Lumen/Watt High Power
906	1090lm/10W	1970lm/17W
1267	1530lm/14W	2760lm/24W
1628	1960lm/17W	3540lm/31W
1990	2400lm/22W	4330lm/38W

L mm	Lumen/Watt Medium Power	Lumen/Watt High Power
890	1160lm/10W	1650lm/14W
1182	1550lm/13W	2210lm/19W
1475	1940lm/16W	2760lm/23W
1765	2330lm/20W	3310lm/28W
2055	2720lm/24W	3860lm/33W

L mm	Lumen/Watt Medium Power	Lumen/Watt High Power
890	790lm/7W	1180lm/9W
1182	1050lm/8W	1570lm/12W
1475	1320lm/10W	1960lm/14W
1765	1580lm/12W	2360lm/17W
2055	1840lm/15W	2750lm/21W

Lumen Values: Luminarie luminous flux at 4000K/CRI>80. Other configurations on request.

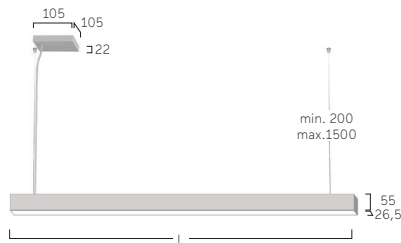

Matric 25mm as a customised System.  
 Regressed 48V track, black anodised inner frame.  
 Outer frame: surface on request.  
 Available Insets: Midpin Spotlights,  
 Lens-Louvre, Opal, Wallwasher.



W Snow White  
A Satin Silver

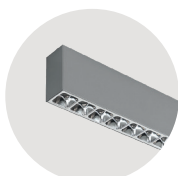

A Satin Silver



W Snow White  
B Jet Black

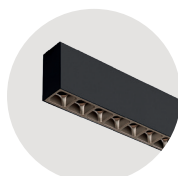

B Jet Black  
X Satin Bronze

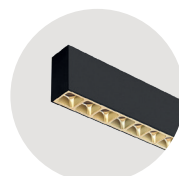

B Jet Black  
G Satin Gold



V Ivory White  
X Satin Bronze

# Matric RQ | System 25 mm Suspended

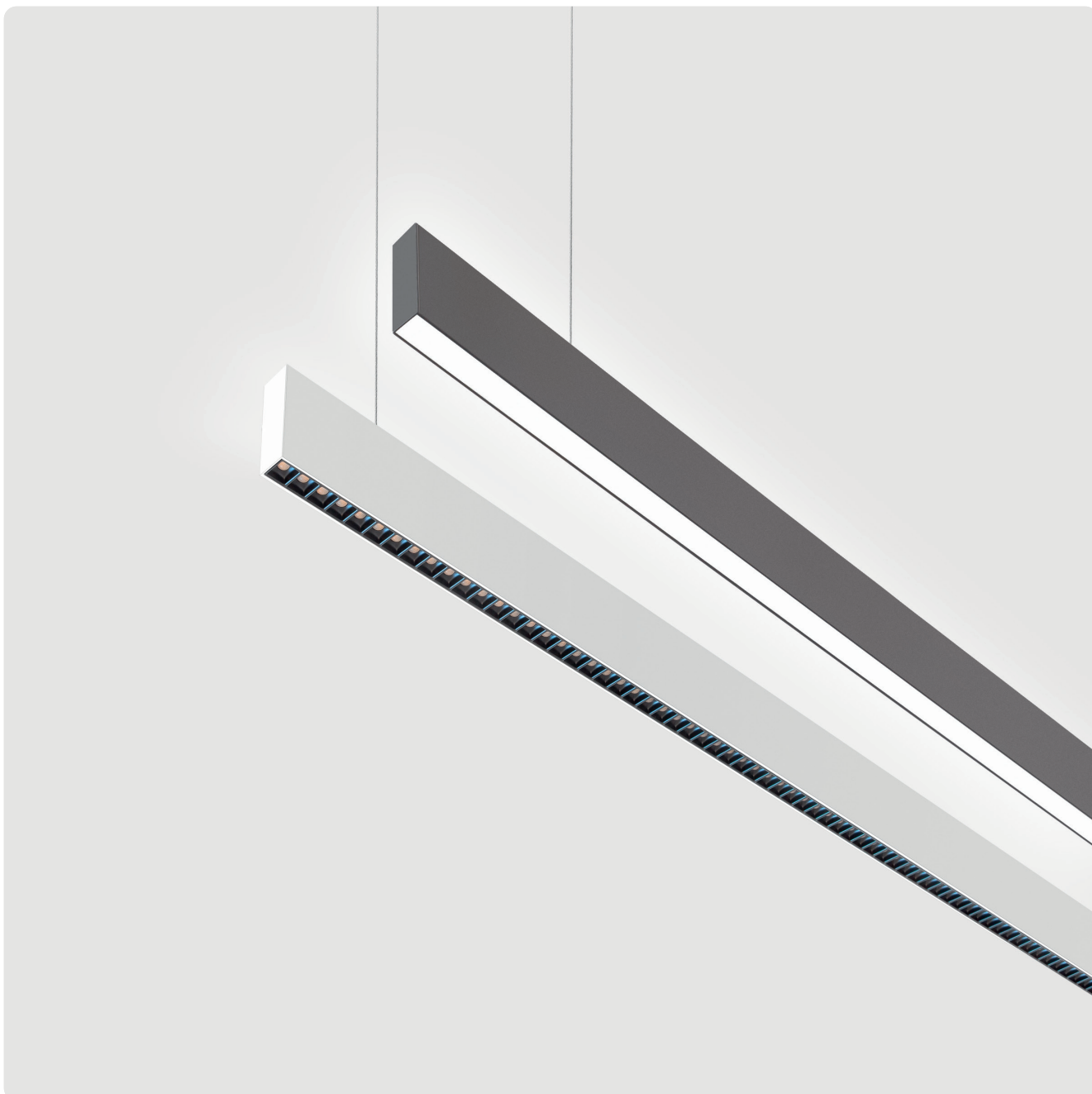

**DE** LED-Pendelleuchte. Direkt-indirektstrahlend. Lichtkanal aus Aluminiumprofil mit 25mm Optikbreite. Millimetergenaue Längenfertigung nach Vorgabe möglich. Oberfläche natureloxiert oder weiß, graphit, schwarz, bronze oder kupferfarben lackiert. Weitere Oberflächenoptionen siehe Lightnet-Surface-Collection oder RAL nach Wahl. Direktanteil über Präzisionslinsen mit Abblenderaster für breite rotationssymmetrische Lichtstärkeverteilung bei gleichzeitig hoher Blendungsbegrenzung (UGR<19) für Office Anwendungen. Abblenderaster in verschiedenen Farbkombinationen erhältlich. Satiniertes Opaldiffusor für Allgemeinbeleuchtung mit max. Transmissionsgrad und homogener Lichtpunktauflösung. Wallwasher für homogene Beleuchtung vertikaler Flächen. Konverter in Leuchtgehäuse integriert, Lichtkammern für direktes und indirektes Licht getrennt schaltbar oder dimmbar (DALI, Casambi). Farbtemperatur 2200K, 2700K, 3000K, 3500K, 4000K, 6500K oder Tunable White (2700-6500K). Binning initial  $\leq$  MacAdam 3. Farbwiedergabe CRI>80, CRI>90 oder Full Spectrum. Stufenlos höhenverstellbare Seilabhängung mit transparent ummantelter Zuleitung. Lackierung Baldachin passend Leuchtenkörper. Auf Anfrage: Integration von Stromschienen und Strahlern, Sensortechnologie.

**EN** LED pendant luminaire. Direct-indirect light distribution. Light channel made of aluminium profile with 25mm optic width. Bespoke lengths are possible. Surface natural anodised or white, graphite, black, bronze or copper coated. For further surface options see Lightnet-Surface-Collection or RAL of your choice. Direct light using precision lenses with louvre for wide uniform symmetrical light distribution with high glare limitation (UGR<19) for workplaces. Louvre available in various colour finishes. Satin opal diffuser for general lighting with maximum transmittance and uniformity. Wallwasher for homogeneous illumination of vertical surfaces. Driver integrated into luminaire housing, light chambers for direct and indirect light separately switchable or dimmable (DALI, Casambi). Colour temperature 2200K, 2700K, 3000K, 3500K, 4000K, 6500K or Tunable White (2700-6500K). Binning  $\leq$  MacAdam 3. Colour rendering CRI>80, CRI>90 or Full Spectrum. Height-adjustable cord suspension with transparent power supply cable. Ceiling rose colour to match luminaire body. On request: Integration of tracks and spotlights, sensor technology.

**LRQLWE-8 30E-L1475-AW**

Product Family	L: Matric
Type	RQ: Direct-indirect
Optical System	O: Opal Diffuser, G: Wallwasher, L: Lens Louvre*
Surface Finish	W: Snow White, Y: Black Anodised, V: Ivory White, F: Anodic Silver, M: Satin Cloud, X: Satin Bronze
Control Gear	E: On/Off, L: DALI, C: Casambi, 6: DALI DT6 for TW, 8: DALI DT8 for TW
Colour Rendering	8: CRI>80, 9: CRI>90, F: Full Spectrum [except 2200K]
Colour Temperature	22: 2200K, 27: 2700K, 30: 3000K, 35: 3500K, 40: 4000K, 65: 6500K, TW: Tunable White 2700-6500K
Power	E: Low Power, M: Medium Power, H: High Power
Size	Luminaire Length in mm (Opal Diffuser, Wallwasher): <b>L890, L1182, L1475, L1765, L2055</b> Luminaire Length in mm (Lens Louvre*): <b>L906, L1267, L1628, L1990</b>
Suspension	A: Single Cord Suspension
Louvre Surface	W: Snow White, D: Anodic Black, F: Anodic Silver, V: Ivory White, M: Satin Cloud, K: Satin Copper, G: Satin Gold, J: Satin Pale Gold, L: Satin Cupria



**Lens Louvre | Direct-Indirect**

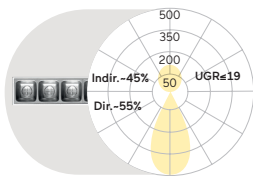

L mm	Lumen/Watt Low Power	Lumen/Watt High Power
906	1880lm/17W	3550lm/30W
1267	2720lm/23W	5130lm/43W
1628	3550lm/30W	6700lm/55W
1990	4290lm/37W	8080lm/67W

**Opal Diffuser | Direct-Indirect**

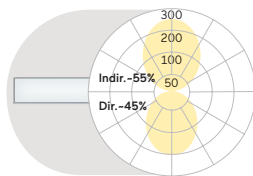

L mm	Lumen/Watt Medium Power	Lumen/Watt High Power
890	2580lm/22W	3540lm/30W
1182	3500lm/29W	4810lm/39W
1475	4430lm/36W	6060lm/49W
1765	5350lm/43W	7320lm/59W
2055	6270lm/51W	8580lm/71W

**Wallwasher | Direct-Indirect**

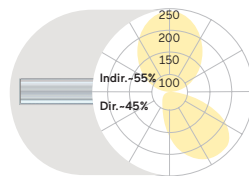

L mm	Lumen/Watt Medium Power	Lumen/Watt High Power
890	1740lm/15W	2600lm/21W
1182	2360lm/19W	3520lm/27W
1475	2990lm/24W	4450lm/34W
1765	3610lm/28W	5380lm/41W
2055	4220lm/34W	6300lm/48W

Lumen Values: Luminaire luminous flux at 4000K/CRI>80. Other configurations on request.

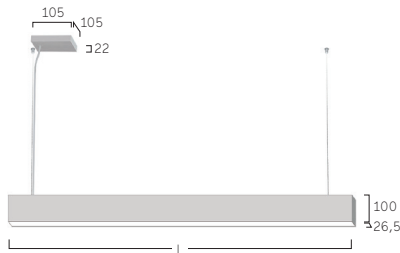

Matric 25mm as a customised System.  
 Regressed 48V track, black anodised inner frame.  
 Outer frame: surface on request.  
 Available Insets: Midpin Spotlights,  
 Lens-Louvre, Opal, Wallwasher.



W Snow White  
A Satin Silver



A Satin Silver  
A Satin Silver



W Snow White  
B Jet Black

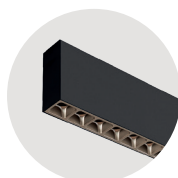

B Jet Black  
X Satin Bronze

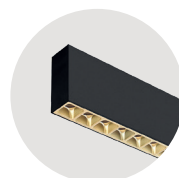

B Jet Black  
G Satin Gold



V Ivory White  
X Satin Bronze

## Matric AQ | System 25mm Surface



**DE** LED-Anbauleuchte für Wand- oder Deckenmontage. Rein direktstrahlend. Lichtkanal aus Aluminiumprofil mit 25mm Optikbreite. Millimetergenaue Längenfertigung nach Vorgabe möglich. Oberfläche natureloxiert oder weiß, graphit, schwarz, bronze oder kupferfarben lackiert. Weitere Oberflächenoptionen siehe Lightnet-Surface-Collection oder RAL nach Wahl. Direktanteil über Präzisionslinsen mit Abblenderaster für breite rotationssymmetrische Lichtstärkeverteilung bei gleichzeitig hoher Blendungsbegrenzung (UGR<19) für Office Anwendungen. Abblenderaster in verschiedenen Farbkombinationen erhältlich. Satinierter Opaldiffusor für Allgemeinbeleuchtung mit max. Transmissionsgrad und homogener Lichtpunktauflösung. Wallwasher für homogene Beleuchtung vertikaler Flächen. Konverter in Leuchtgehäuse integriert, wahlweise einfach schaltbar oder stufenlos dimmbar (DALI, Touch-Dim, Casambi). Farbtemperatur 2200K, 2700K, 3000K, 3500K, 4000K, 6500K oder Tunable White (2700-6500K). Binning initial  $\leq$  MacAdam 3. Farbwiedergabe CRI>80, CRI>90 oder Full Spectrum. Auf Anfrage: Integration von Stromschienen und Strahlern, Sensortechnologie.

**EN** LED surface-mounted luminaire for walls or ceilings. Direct only light distribution. Light channel made of aluminium profile with 25mm optic width. Bespoke lengths are possible. Surface natural anodised or white, graphite, black, bronze or copper coated. For further surface options see Lightnet-Surface-Collection or RAL of your choice. Direct light using precision lenses with louvre for wide uniform symmetrical light distribution with high glare limitation (UGR<19) for workplaces. Louvre available in various colour finishes. Satin opal diffuser for general lighting with maximum transmittance and homogeneous lighting. Wallwasher for homogeneous illumination of vertical surfaces. Driver integrated into luminaire housing available as switched or dimmable (DALI, Touch-Dim, Casambi). Colour temperature 2200K, 2700K, 3000K, 3500K, 4000K, 6500K or Tunable White (2700-6500K). Binning  $\leq$  MacAdam 3. Colour rendering CRI>80, CRI>90 or Full Spectrum. On request: Integration of tracks and spotlights, sensor technology.

**L AQLWE-8 30E-L1475-D**

Product Family **L:** Matric

Type **AQ:** Direct only

Optical System **O:** Opal Diffuser, **G:** Wallwasher, **L:** Lens Louvre\*

Surface Finish **W:** Snow White, **Y:** Black Anodised, **V:** Ivory White, **F:** Anodic Silver, **M:** Satin Cloud, **X:** Satin Bronze

Control Gear **E:** On/Off, **L:** DALI, **C:** Casambi, **6:** DALI DT6 for TW, **8:** DALI DT8 for TW

Colour Rendering **8:** CRI>80, **9:** CRI>90, **F:** Full Spectrum [except 2200K]

Colour Temperature **22:** 2200K, **27:** 2700K, **30:** 3000K, **35:** 3500K, **40:** 4000K, **65:** 6500K, **TW:** Tunable White 2700-6500K

Power **E:** Low Power, **M:** Medium Power, **H:** High Power

Size Luminaire Length in mm (Opal Diffuser, Wallwasher): **L890, L1182, L1475, L1765, L2055**  
 Luminaire Length in mm (Lens Louvre\*): **L906, L1267, L1628, L1990**

Louvre Surface **W:** Snow White, **D:** Anodic Black, **F:** Anodic Silver, **V:** Ivory White, **M:** Satin Cloud, **K:** Satin Copper, **G:** Satin Gold, **J:** Satin Pale Gold, **L:** Satin Cupria

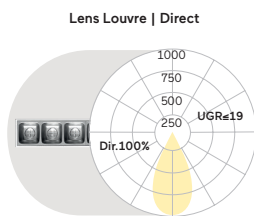

L mm	Lumen/Watt Low Power	Lumen/Watt High Power
906	1090lm/10W	1970lm/17W
1267	1530lm/14W	2760lm/24W
1628	1960lm/17W	3540lm/31W
1990	2400lm/22W	4330lm/38W

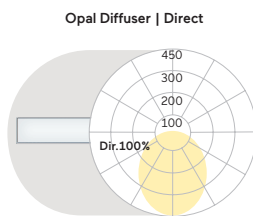

L mm	Lumen/Watt Medium Power	Lumen/Watt High Power
890	1160lm/10W	1650lm/14W
1182	1550lm/13W	2210lm/19W
1475	1940lm/16W	2760lm/23W
1765	2330lm/20W	3310lm/28W
2055	2720lm/24W	3860lm/33W

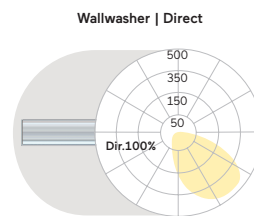

L mm	Lumen/Watt Medium Power	Lumen/Watt High Power
890	790lm/7W	1180lm/9W
1182	1050lm/8W	1570lm/12W
1475	1320lm/10W	1960lm/14W
1765	1580lm/12W	2360lm/17W
2055	1840lm/15W	2750lm/21W

Lumen Values: Luminaire luminous flux at 4000K/CRI>80. Other configurations on request.



Matric 25mm as a customised System.  
 Regressed 48V track, black anodised inner frame.  
 Outer frame: surface on request.  
 Available Insets: Midpin Spotlights,  
 Lens-Louvre, Opal, Wallwasher.



**W** Snow White  
**A** Satin Silver



**A** Satin Silver



**W** Snow White  
**B** Jet Black

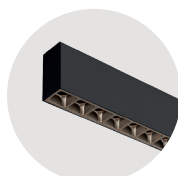

**B** Jet Black  
**X** Satin Bronze

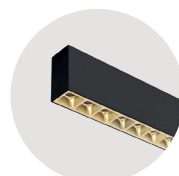

**B** Jet Black  
**G** Satin Gold



**V** Ivory White  
**X** Satin Bronze



# Matric MQ | System 25mm Recessed Frameless



**DE** LED-Einbauleuchte für rahmenlose Montage in Gipskartondecken. Rein direktstrahlend. Lichtkanal aus Aluminiumprofil mit 25mm Optikbreite. Millimetergenaue Längenfertigung nach Vorgabe möglich. Direktanteil über Präzisionslinsen mit Abblendraster für breite rotationssymmetrische Lichtstärkeverteilung bei gleichzeitig hoher Blendungsbegrenzung ( $UGR < 19$ ) für Office Anwendungen. Abblendraster in verschiedenen Farbkombinationen erhältlich. Satinierter Opaldiffusor für Allgemeinbeleuchtung mit max. Transmissionsgrad und homogener Lichtpunktauflösung. Wallwasher für homogene Beleuchtung vertikaler Flächen. Konverter in Leuchtengehäuse integriert, wahlweise einfach schaltbar oder stufenlos dimmbar (DALI, Touch-Dim, Casambi). Farbtemperatur 2200K, 2700K, 3000K, 3500K, 4000K, 6500K oder Tunable White (2700-6500K). Binning initial  $\leq$  MacAdam 3. Farbwiedergabe  $CRI > 80$ ,  $CRI > 90$  oder Full Spectrum. Einbaurahmen oder Leuchtenprofil für Montage vorab lieferbar; restliche Leuchtenkomponenten zeitlich versetzt montierbar. Auf Anfrage: Integration von Stromschienen und Strahlern, Sensortechnologie.

**EN** Recessed mounted LED luminaire for frameless installation in plasterboard ceilings. Direct only light distribution. Light channel made of aluminium profile with 25mm optic width. Bespoke lengths are possible. Direct light using precision lenses with louvre for wide uniform symmetrical light distribution with high glare limitation ( $UGR < 19$ ). Louvre available in various colour finishes. Satin opal diffuser for general lighting with maximum transmittance and homogeneous lighting. Wallwasher for homogeneous illumination of vertical surfaces. Driver integrated into luminaire housing, available as switched or dimmable (DALI, Touch-Dim, Casambi). Colour temperature 2200K, 2700K, 3000K, 3500K, 4000K, 6500K or Tunable White (2700-6500K). Binning  $\leq$  MacAdam 3. Colour rendering  $CRI > 80$ ,  $CRI > 90$  or Full Spectrum. Mounting frame or luminaire profile available in advance for mounting; other luminaire components can be mounted later. On request: Integration of tracks and spotlights, sensor technology.

**LMQLWE-8 30E-L1486-D**

Product Family **L:** Matric

Type **MQ:** Direct only

Optical System **O:** Opal Diffuser, **G:** Wallwasher, **L:** Lens Louvre\*

Surface Finish **W:** Snow White, **Y:** Black Anodised, **V:** Ivory White, **F:** Anodic Silver, **M:** Satin Cloud, **X:** Satin Bronze

Control Gear **E:** On/Off, **L:** DALI, **H:** Touch-Dim, **C:** Casambi, **6:** DALI DT6 for TW, **8:** DALI DT8 for TW

Colour Rendering **8:** CRI>80, **9:** CRI>90, **F:** Full Spectrum [except 2200K]

Colour Temperature **22:** 2200K, **27:** 2700K, **30:** 3000K, **35:** 3500K, **40:** 4000K, **65:** 6500K, **TW:** Tunable White 2700-6500K

Power **E:** Low Power, **M:** Medium Power, **H:** High Power

Size Luminaire Length in mm (Opal Diffuser, Wallwasher): **L890, L1182, L1475, L1765, L2055**  
 Luminaire Length in mm (Lens Louvre\*): **L906, L1267, L1628, L1990**

Louvre Surface **W:** Snow White, **D:** Anodic Black, **F:** Anodic Silver, **V:** Ivory White, **M:** Satin Cloud, **K:** Satin Copper, **G:** Satin Gold, **J:** Satin Pale Gold, **L:** Satin Cupria



Lens Louvre   Direct			Opal Diffuser   Direct			Wallwasher   Direct		
L mm	Lumen/Watt Low Power	Lumen/Watt High Power	L mm	Lumen/Watt Medium Power	Lumen/Watt High Power	L mm	Lumen/Watt Medium Power	Lumen/Watt High Power
906	1090lm/10W	1970lm/17W	890	1160lm/10W	1650lm/14W	890	790lm/7W	1180lm/9W
1267	1530lm/14W	2760lm/24W	1182	1550lm/13W	2210lm/19W	1182	1050lm/8W	1570lm/12W
1628	1960lm/17W	3540lm/31W	1475	1940lm/16W	2760lm/23W	1475	1320lm/10W	1960lm/14W
1990	2400lm/22W	4330lm/38W	1765	2330lm/20W	3310lm/28W	1765	1580lm/12W	2360lm/17W
			2055	2720lm/24W	3860lm/33W	2055	1840lm/15W	2750lm/21W

Lumen Values: Luminaire luminous flux at 4000K/CRI>80. Other configurations on request.

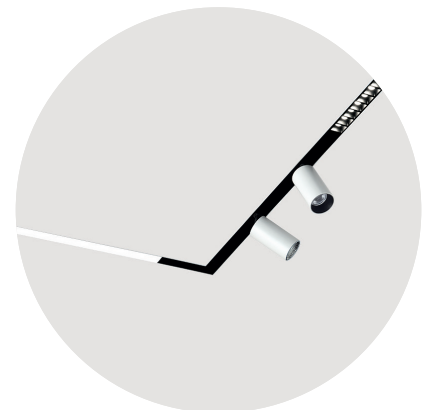
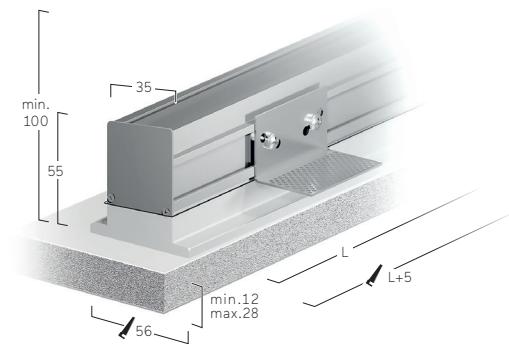

Matric 25mm as a customised System.  
 Regressed 48V track, black anodised inner frame.  
 Outer frame: surface on request.  
 Available Insets: Midpin Spotlights, Lens-Louvre, Opal, Wallwasher.

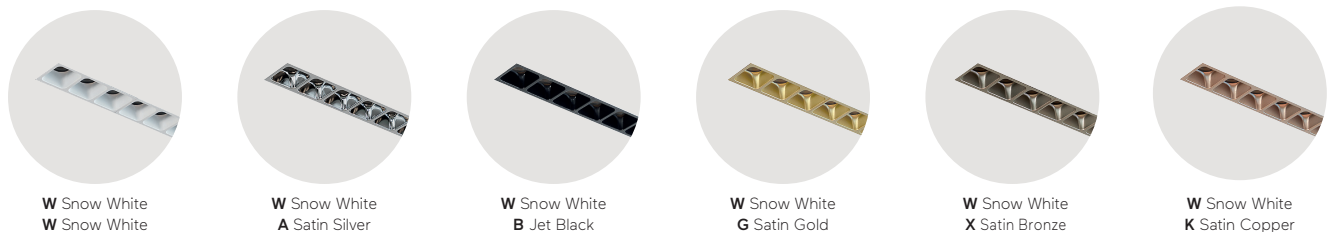

## Matric FQ | System 25mm Recessed Frame

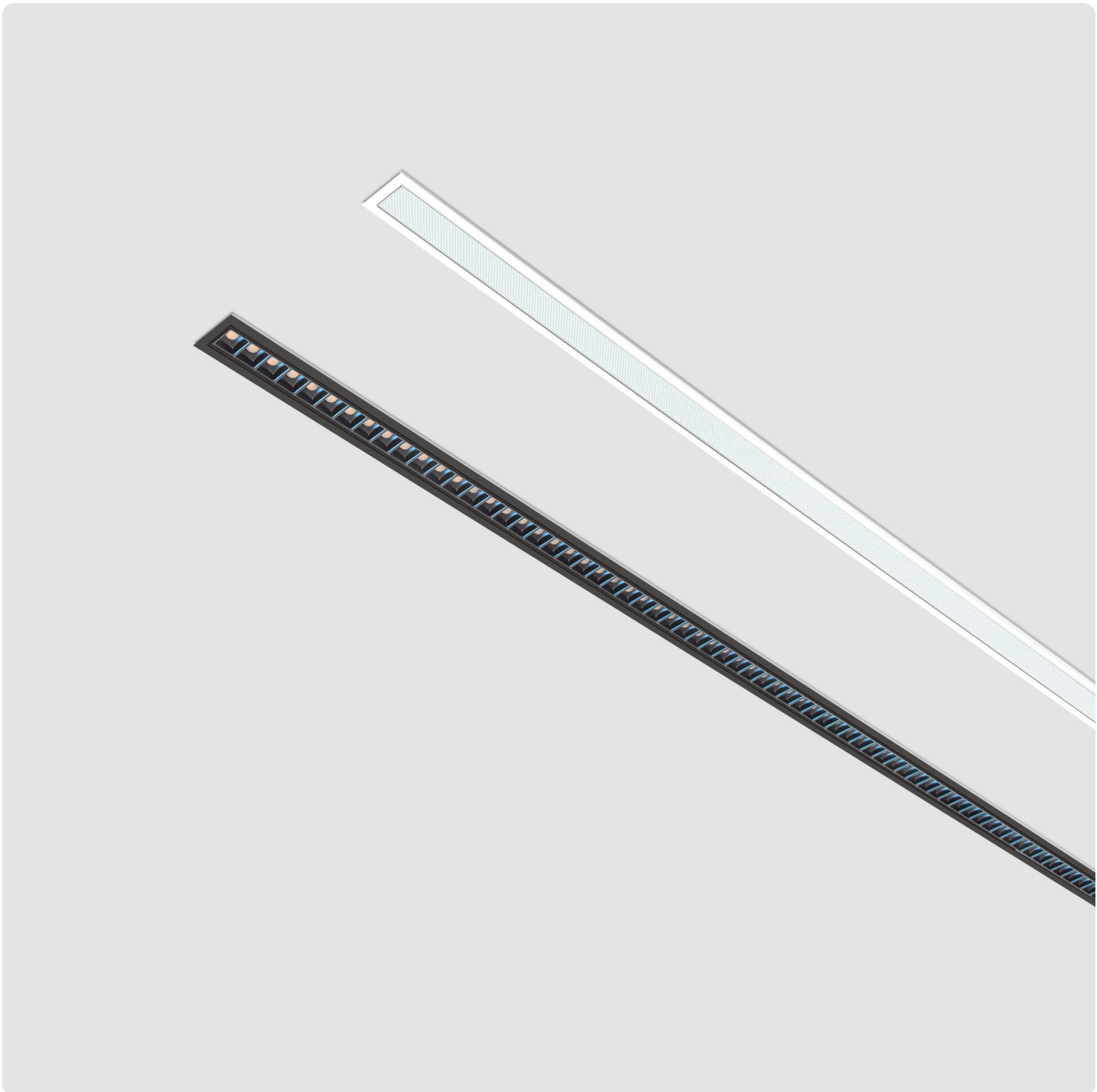

**DE** LED-Einbauleuchte für Montage in gesägten Deckenöffnungen. Rein direktstrahlend. Lichtkanal mit umlaufendem Rahmen aus Aluminiumprofil. Optikbreite 25mm. Millimetergenaue Längenfertigung nach Vorgabe möglich. Oberfläche natureloxiert oder weiß, graphit, schwarz, bronze oder kupferfarben lackiert. Weitere Oberflächenoptionen siehe Lightnet-Surface-Collection oder RAL nach Wahl. Direktanteil über Präzisionslinsen mit Abblenderaster für breite rotationssymmetrische Lichtstärkeverteilung bei gleichzeitig hoher Blendungsbegrenzung (UGR<19) für Office Anwendungen. Abblenderaster in verschiedenen Farbkombinationen erhältlich. Satinierter Opaldiffusor für Allgemeinbeleuchtung mit max. Transmissionsgrad und homogener Lichtpunktauflösung. Wallwasher für homogene Beleuchtung vertikaler Flächen. Konverter in Leuchtengehäuse integriert, wahlweise einfach schaltbar oder stufenlos dimmbar (DALI, Touch-Dim, Casambi). Farbtemperatur 2200K, 2700K, 3000K, 3500K, 4000K, 6500K oder Tunable White (2700-6500K). Binning initial  $\leq$  MacAdam 3. Farbwiedergabe CRI>80, CRI>90 oder Full Spectrum. Befestigungsset inklusive. Leuchtenprofil für Montage auf Anfrage vorab lieferbar; restliche Leuchtenkomponenten zeitlich versetzt montierbar. Auf Anfrage: Integration von Sensortechnologie.

**EN** Recessed mounted LED luminaire for installation in ceiling cut-outs openings. Direct only light distribution. Light channel with surrounding frame made of aluminium profile. Optic width 25mm. Bespoke lengths are possible. Surface natural anodised, white, graphite, black, bronze or copper coated. For further surface options see Lightnet-Surface-Collection or RAL of your choice. Direct light using precision lenses with louvre for wide uniform symmetrical light distribution with high glare limitation (UGR<19) for workplaces. Louvre available in various colour finishes. Satin opal diffuser for general lighting with maximum transmittance and uniformity. Wallwasher for homogeneous illumination of vertical surfaces. Driver integrated into luminaire housing, available as switched or dimmable (DALI, Touch-Dim, Casambi). Colour temperature 2200K, 2700K, 3000K, 3500K, 4000K, 6500K or Tunable White (2700-6500K). Binnings  $\leq$  MacAdam 3. Colour rendering CRI>80, CRI>90 or Full Spectrum. Mounting brackets included. Luminaire profile available in advance for mounting; other luminaire components can be mounted later. On request: Integration of sensor technology.

**L F Q L W E - 8 3 0 E - L 1 2 7 8 - D**

Product Family	<b>L:</b> Matric
Type	<b>FQ:</b> Direct only
Optical System	<b>O:</b> Opal Diffuser, <b>G:</b> Wallwasher, <b>L:</b> Lens Louvre*
Surface Finish	<b>W:</b> Snow White, <b>Y:</b> Black Anodised, <b>V:</b> Ivory White, <b>F:</b> Anodic Silver, <b>M:</b> Satin Cloud, <b>X:</b> Satin Bronze
Control Gear	<b>E:</b> On/Off, <b>L:</b> DALI, <b>H:</b> Touch-Dim, <b>C:</b> Casambi, <b>6:</b> DALI DT6 for TW, <b>8:</b> DALI DT8 for TW
Colour Rendering	<b>8:</b> CRI>80, <b>9:</b> CRI>90, <b>F:</b> Full Spectrum [except 2200K]
Colour Temperature	<b>22:</b> 2200K, <b>27:</b> 2700K, <b>30:</b> 3000K, <b>35:</b> 3500K, <b>40:</b> 4000K, <b>65:</b> 6500K, <b>TW:</b> Tunable White 2700-6500K
Power	<b>E:</b> Low Power, <b>M:</b> Medium Power, <b>H:</b> High Power
Size	Luminaire Length in mm (Opal Diffuser, Wallwasher): <b>L901, L1193, L1486, L2066</b> Luminaire Length in mm (Lens Louvre*): <b>L917, L1278, L1639, L2000</b>
Louvre Surface	<b>W:</b> Snow White, <b>D:</b> Anodic Black, <b>F:</b> Anodic Silver, <b>V:</b> Ivory White, <b>M:</b> Satin Cloud, <b>K:</b> Satin Copper, <b>G:</b> Satin Gold, <b>J:</b> Satin Pale Gold, <b>L:</b> Satin Cupria

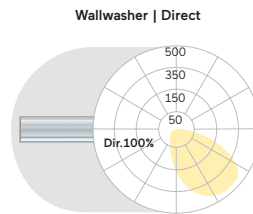
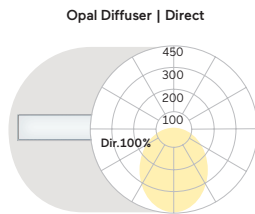
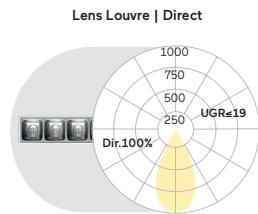

L mm	Lumen/Watt Low Power	Lumen/Watt High Power
917	1090lm/10W	1970lm/17W
1278	1530lm/14W	2760lm/24W
1639	1960lm/17W	3540lm/31W
2000	2400lm/22W	4330lm/38W

L mm	Lumen/Watt Medium Power	Lumen/Watt High Power
901	1160lm/10W	1650lm/14W
1193	1550lm/13W	2210lm/19W
1486	1940lm/16W	2760lm/23W
1776	2330lm/20W	3310lm/28W
2066	2720lm/24W	3860lm/33W

L mm	Lumen/Watt Medium Power	Lumen/Watt High Power
901	790lm/7W	1180lm/9W
1193	1050lm/8W	1570lm/12W
1486	1320lm/10W	1960lm/14W
1776	1580lm/12W	2360lm/17W
2066	1840lm/15W	2750lm/21W

Lumen Values: Luminaire luminous flux at 4000K/CRI>80. Other configurations on request.

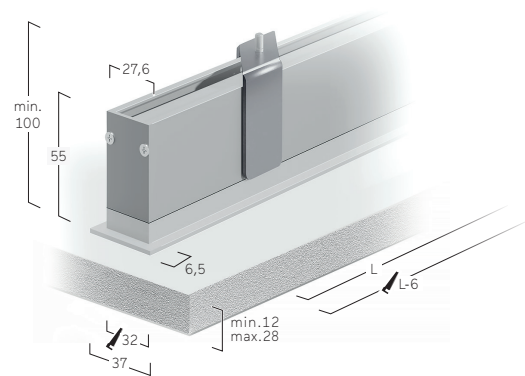

Matric 25mm as a customised System.  
 Regressed 48V track, black anodised inner frame.  
 Outer frame: surface on request.  
 Available Insets: Midpin Spotlights, Lens-Louvre, Opal, Wallwasher.



**B** Jet Black  
**W** Snow White



**B** Jet Black  
**A** Satin Silver



**B** Jet Black  
**B** Jet Black

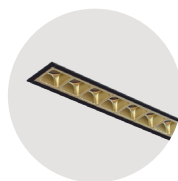

**B** Jet Black  
**G** Satin Gold



**B** Jet Black  
**X** Satin Bronze



**B** Jet Black  
**K** Satin Copper

# Matric G7/P7 | System 81mm Suspended

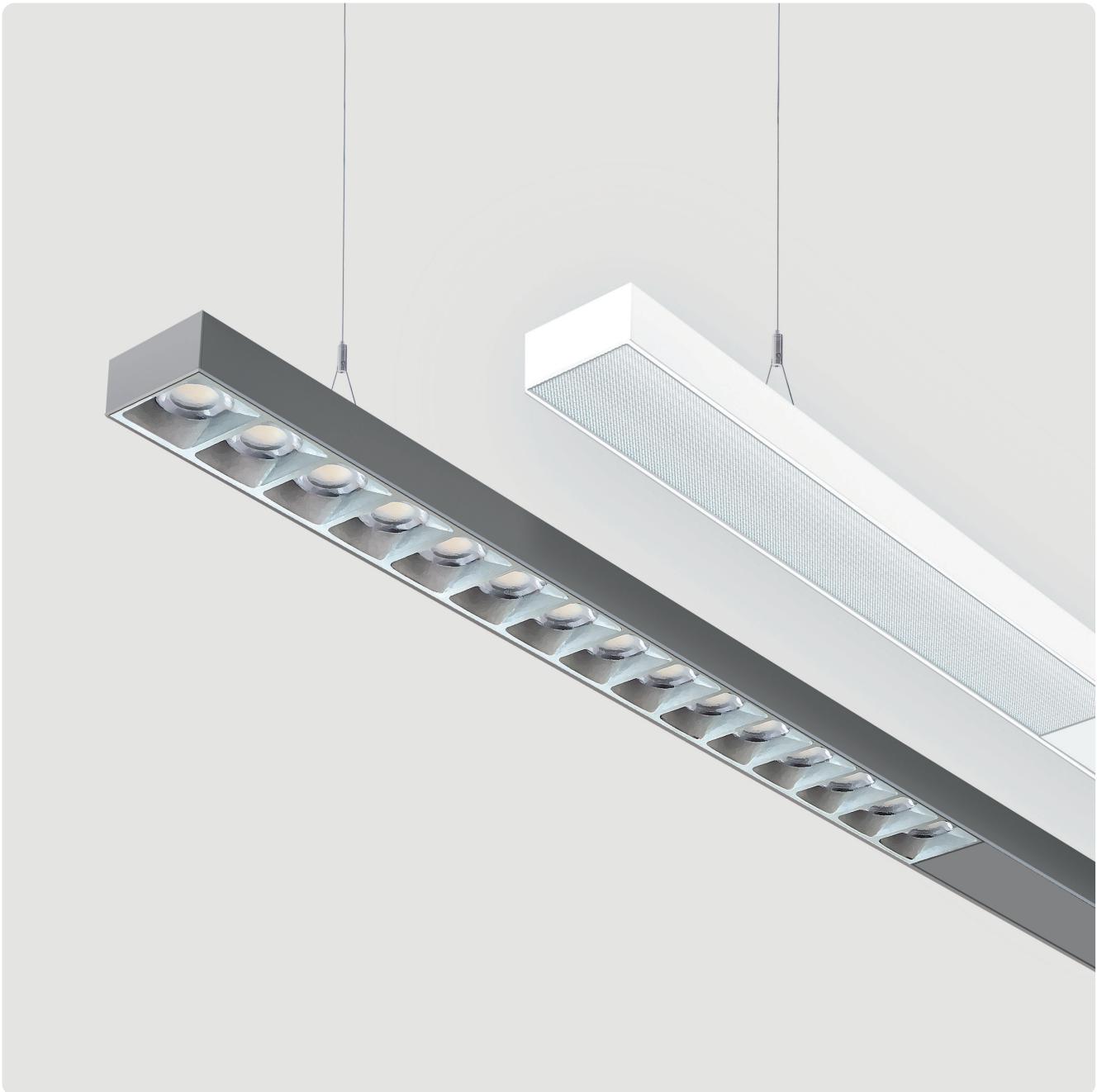

**DE** LED-Pendelleuchte. Direkt-indirektstrahlend (indirektes Licht über die gesamte Leuchtenlänge). Leuchtenkörper aus Aluminiumprofil mit 80mm Optikbreite und 40mm Bauhöhe. Millimetergenaue Längenfertigung nach Vorgabe möglich. Oberfläche natureloxiert oder weiß, graphit, schwarz, bronze oder kupferfarben lackiert. Weitere Oberflächenoptionen siehe Lightnet-Surface-Collection oder RAL nach Wahl. Direktanteil über Präzisionslinsen mit Abblendraster für breite rotationssymmetrische Lichtstärkeverteilung bei gleichzeitig hoher Blendungsbegrenzung (UGR<19) für Office Anwendungen. Abblendraster in verschiedenen Farbkombinationen erhältlich. Alternativ Microprismenoptik aus Spezialacrylglas mit optimierter Blendungsbegrenzung für Office-Anwendungen. Wallwasher für homogene Beleuchtung vertikaler Flächen. Konverter hinter Blindfeldern in Leuchtgehäuse integriert, wahlweise einfach schaltbar oder stufenlos dimmbar (DALI, Touch-Dim, Casambi). Farbtemperatur 2700K, 3000K, 3500K, 4000K, 6500K. Binning initial  $\leq$  MacAdam 3. Farbwiedergabe CRI>80, CRI>90 oder Full Spectrum. Stufenlos höhenverstellbare Seilabhängung mit transparent ummantelter Zuleitung. Lackierung Baldachin passend Leuchtenkörper. Auf Anfrage: Integration von Notlichtkomponenten, Sensortechnologie.

**EN** LED pendant luminaire. Direct-indirect light distribution (indirect light across the entire length of the luminaire). Luminaire body made of aluminium profile with 80mm optic width and 40mm overall height. Bespoke lengths are possible. Surface natural anodised, white, graphite, black, bronze or copper coated. For further surface options see Lightnet-Surface-Collection or RAL of your choice. Direct light using precision lenses with louvre for wide uniform symmetrical light distribution with high glare limitation (UGR<19) for workplaces. Louvre available in various colour finishes. Alternatively, Microprismatic diffuser made of special acrylic glass with optimized glare reduction for workplaces. Wallwasher for homogeneous illumination of vertical surfaces. Driver integrated into luminaire housing behind blind bays, available as switched or dimmable (DALI, Touch-Dim, Casambi). Colour temperature 2700K, 3000K, 3500K, 4000K or 6500K. Binning  $\leq$  MacAdam 3. Colour rendering CRI>80, CRI>90 or Full Spectrum. Height-adjustable cord suspension with transparent power supply cable. Ceiling rose colour to match luminaire body. On request: Integration of emergency lighting components, sensor technology.

**LP7LWE-830M-L3000-YF**

Product Family: L: Matric

Type: **G7:** Direct only, **P7:** Direct-indirect

Optical System: **A:** Microprismatic, **O:** Opal Diffuser, **L:** Lens Louvre\*

Surface Finish: **W:** Snow White, **V:** Ivory White, **E:** Silver Anodised, **U:** Urban Graphite, **B:** Jet Black, **X:** Satin Bronze, **K:** Satin Copper

Control Gear: **E:** On/Off, **L:** DALI, **H:** Touch-Dim, **M:** Multisensor, **C:** Casambi, **6:** DALI DT6 for TW, **8:** DALI DT8 for TW

Colour Rendering: **8:** CRI>80, **9:** CRI>90, **F:** Full Spectrum [except 2200K]

Colour Temperature: **22:** 2200K, **27:** 2700K, **30:** 3000K, **35:** 3500K, **40:** 4000K, **65:** 6500K, **TW:** Tunable White 2700-6500K

Power: **E:** Low Power, **M:** Medium Power

Size: Luminaire Length in mm (Microprismatic, Opal Diffuser): 1- Length **L1310, L1505, L1795**; 2- Lengths **L2470, L2860**  
Luminaire Length in mm (Lens Louvre\*): 1- Length **L1335, L1585, L1836**; 2- Lengths **L2500, L3000**

Suspension: **Y:** Y-Cord Suspension

Lens Louvre\*: **W:** Snow White, **D:** Anodic Black, **F:** Anodic Silver, **V:** Ivory White, **M:** Satin Cloud, **K:** Satin Copper, **G:** Satin Gold, **J:** Satin Pale Gold, **L:** Satin Cupria



Lens Louvre | Direct

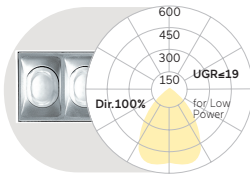

L mm	Lenghts	Lumen/Watt Low Power	Lumen/Watt Medium Power
1335	1	2170lm/16W	4330lm/30W
1585	1	2710lm/21W	5420lm/38W
1836	1	3260lm/24W	6500lm/46W
2500	2	4340lm/33W	8670lm/61W
3000	2	5430lm/40W	10830lm/76W

Microprismatic | Direct

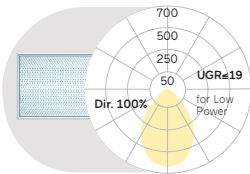

L mm	Lenghts	Lumen/Watt Low Power	Lumen/Watt Medium Power
1310	1	1740lm/15W	2430lm/21W
1505	1	2090lm/18W	2920lm/25W
1795	1	2610lm/23W	3650lm/32W
2470	2	3480lm/30W	4870lm/43W
2860	2	4180lm/37W	5840lm/51W

Opal Diffuser | Direct

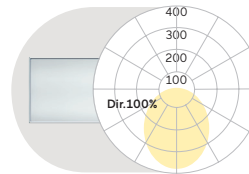

L mm	Lenghts	Lumen/Watt Low Power	Lumen/Watt Medium Power
1310	1	2280lm/15W	3190lm/21W
1505	1	2740lm/18W	3830lm/25W
1795	1	3420lm/23W	4780lm/32W
2470	2	4560lm/30W	6380lm/43W
2860	2	5470lm/37W	7650lm/51W

Lens Louvre | Direct-Indirect

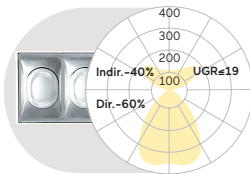

L mm	Lenghts	Lumen/Watt Low Power	Lumen/Watt Medium Power
1335	1	3710lm/26W	7370lm/49W
1585	1	4640lm/33W	9220lm/62W
1836	1	5570lm/39W	11060lm/73W
2500	2	7810lm/55W	15510lm/103W
3000	2	9280lm/65W	18430lm/122W

Microprismatic | Direct-Indirect

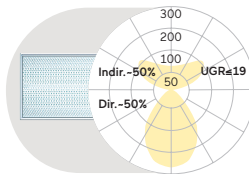

L mm	Lenghts	Lumen/Watt Low Power	Lumen/Watt Medium Power
1310	1	3590lm/27W	5170lm/39W
1505	1	4400lm/33W	6350lm/46W
1795	1	5380lm/40W	7760lm/57W
2470	2	7170lm/53W	10350lm/77W
2860	2	8790lm/65W	12690lm/93W

Opal Diffuser | Direct-Indirect

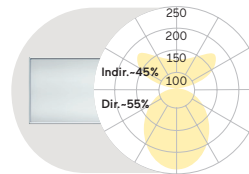

L mm	Lenghts	Lumen/Watt Low Power	Lumen/Watt Medium Power
1310	1	4130lm/27W	5930lm/39W
1505	1	5050lm/33W	7260lm/46W
1795	1	6190lm/40W	8890lm/57W
2470	2	8250lm/53W	11860lm/77W
2860	2	10080lm/65W	14500lm/93W

Lumen Values: Luminaire luminous flux at 4000K/CRI>80. Other configurations on request.

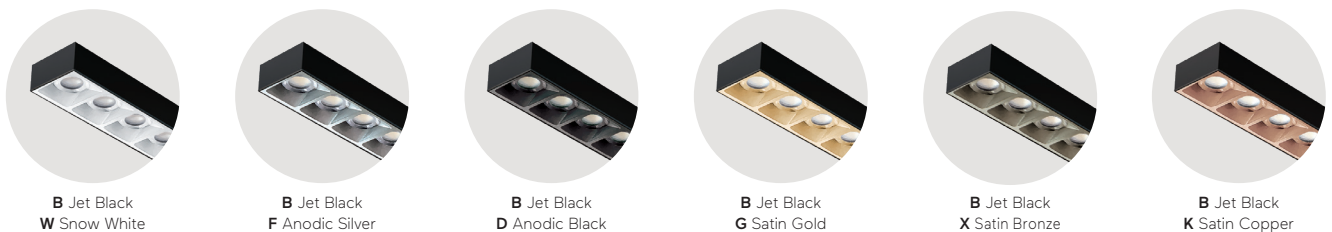
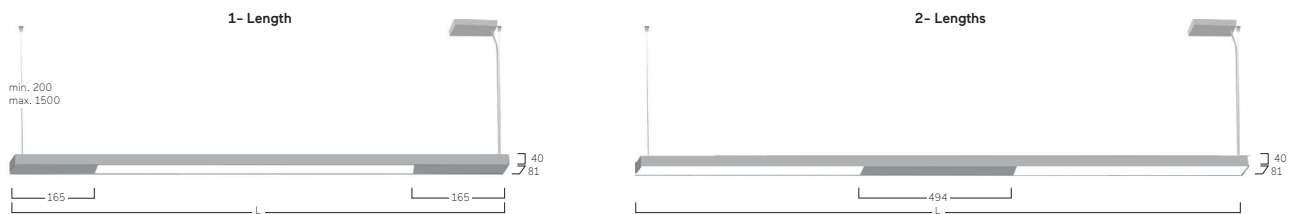

## Matric A7 | System 81mm Surface

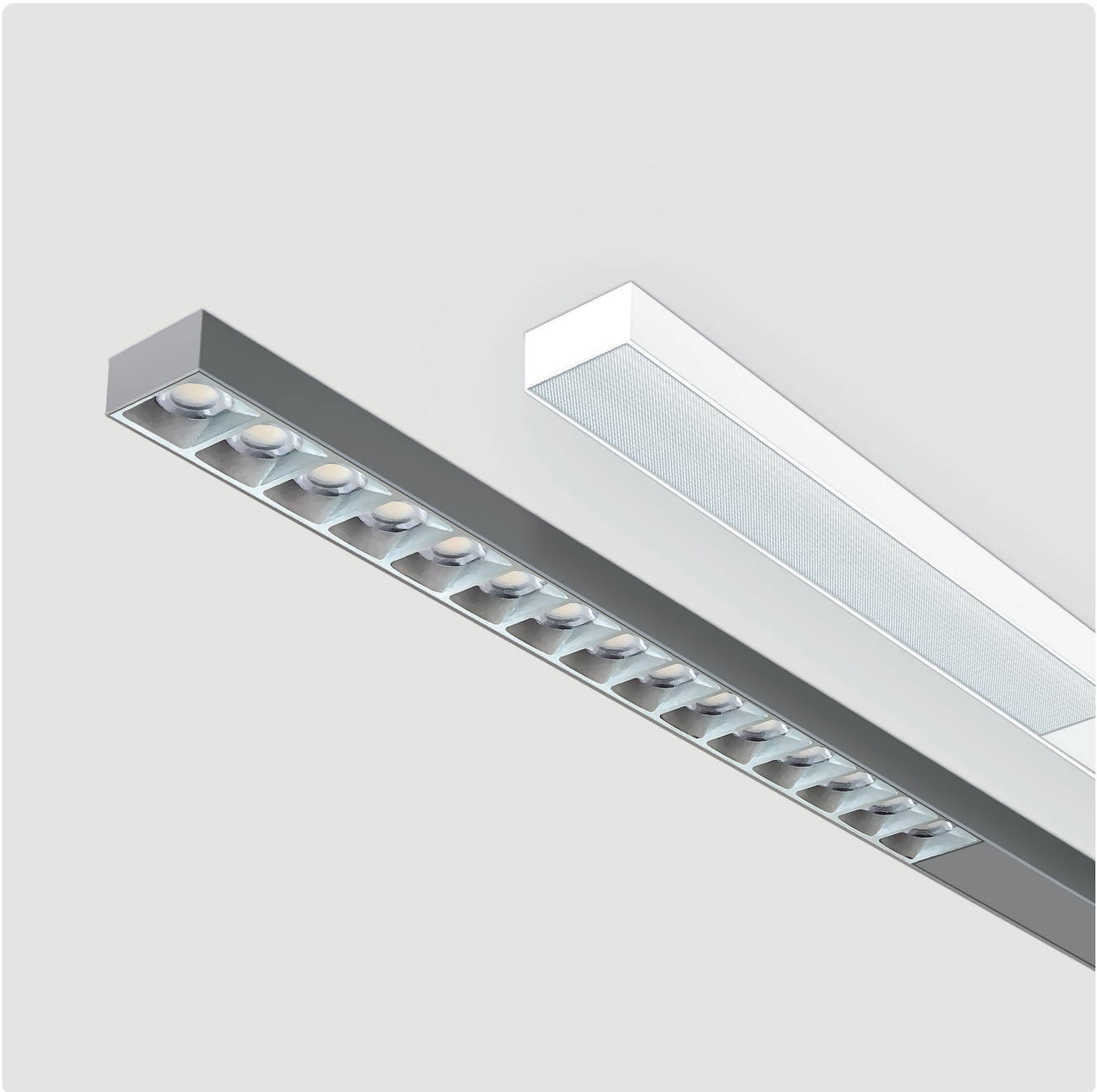

**DE** LED-Anbauleuchte für Wand- oder Deckenmontage. Rein direktstrahlend. Lichtkanal aus Aluminiumprofil mit 80mm Optikbreite und 40mm Bauhöhe. Millimetergenaue Längenfertigung nach Vorgabe möglich. Oberfläche natureloxiert oder weiß, graphit, schwarz, bronze oder kupferfarben lackiert. Weitere Oberflächenoptionen siehe Lightnet-Surface-Collection oder RAL nach Wahl. Direktanteil über Präzisionslinsen mit Abblendraster für breite rotationssymmetrische Lichtstärkeverteilung bei gleichzeitig hoher Blendungsbegrenzung ( $UGR < 19$ ) für Office Anwendungen. Abblendraster in verschiedenen Farbkombinationen erhältlich. Alternativ Microprismenoptik aus Spezialacrylglas mit optimierter Blendungsbegrenzung für Office-Anwendungen. Wallwasher für homogene Beleuchtung vertikaler Flächen. Konverter hinter Blindfeldern in Leuchtengehäuse integriert, wahlweise einfach schaltbar oder stufenlos dimmbar (DALI, Touch-Dim, Casambi). Farbtemperatur 2200K, 2700K, 3000K, 3500K, 4000K, 6500K oder Tunable White (2700-6500K). Binning initial  $\leq$  MacAdam 3. Farbwiedergabe  $CRI > 80$ ,  $CRI > 90$  oder Full Spectrum. Auf Anfrage: Integration von Strahlern, Notlichtkomponenten, Sensortechnologie.

**EN** LED surface-mounted luminaire for walls or ceilings. Direct only light distribution. Light channel made of aluminium profile with 80mm optic width and 40mm overall height. Bespoke lengths are possible. Surface natural anodised or white, graphite, black, bronze or copper coated. For further surface options see Lightnet-Surface-Collection or RAL of your choice. Direct light using precision lenses with louvre for wide uniform symmetrical light distribution with high glare limitation ( $UGR < 19$ ) for workplaces. Louvre available in various colour finishes. Alternatively, Microprismatic diffuser made of special acrylic glass with optimized glare reduction for workplaces. Wallwasher for homogeneous illumination of vertical surfaces. Driver integrated into luminaire housing behind blind bays, available as switched or dimmable (DALI, Touch-Dim, Casambi). Colour temperature 2200K, 2700K, 3000K, 3500K, 4000K, 6500K or Tunable White (2700-6500K). Binnings  $\leq$  MacAdam 3. Colour rendering  $CRI > 80$ ,  $CRI > 90$  or Full Spectrum. On request: Integration of spotlights, emergency lighting components, sensor technology.

**L A7 L W E - 8 30 M - L3000-B**

Product Family	L: Matric
Type	A7: Direct only
Optical System	A: Microprismatic, O: Opal Diffuser, L: Lens Louvre*
Surface Finish	W: Snow White, V: Ivory White, E: Silver Anodised, U: Urban Graphite, B: Jet Black, X: Satin Bronze, K: Satin Copper
Control Gear	E: On/Off, L: DALI, H: Touch-Dim, M: Multisensor, C: Casambi, 6: DALI DT6 for TW, 8: DALI DT8 for TW
Colour Rendering	8: CRI>80, 9: CRI>90, F: Full Spectrum [except 2200K]
Colour Temperature	22: 2200K, 27: 2700K, 30: 3000K, 35: 3500K, 40: 4000K, 65: 6500K, TW: Tunable White 2700-6500K
Power	E: Low Power, M: Medium Power
Size	Luminaire Length in mm (Microprismatic, Opal Diffuser): 1- Length <b>L1310, L1505, L1795</b> ; 2- Lengths <b>L2470, L2860</b>
	Luminaire Length in mm (Lens Louvre*): 1- Length <b>L1335, L1585, L1836</b> ; 2- Lengths <b>L2500, L3000</b>
Lens Louvre*	W: Snow White, D: Anodic Black, F: Anodic Silver, V: Ivory White, M: Satin Cloud, K: Satin Copper, G: Satin Gold, J: Satin Pale Gold, L: Satin Cupria



Lens Louvre | Direct

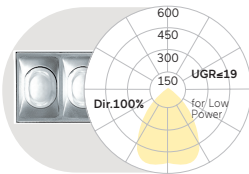

Microprismatic | Direct

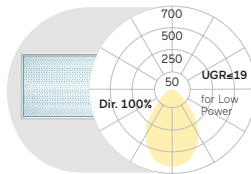

Opal Diffuser | Direct

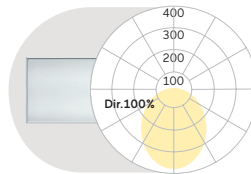

L mm	Lenghts	Lumen/Watt Low Power	Lumen/Watt Medium Power
1335	1	2170lm/16W	4330lm/30W
1585	1	2710lm/21W	5420lm/38W
1836	1	3260lm/24W	6500lm/46W
2500	2	4340lm/33W	8670lm/61W
3000	2	5430lm/40W	10830lm/76W

L mm	Lenghts	Lumen/Watt Low Power	Lumen/Watt Medium Power
1310	1	1740lm/15W	2430lm/21W
1505	1	2090lm/18W	2920lm/25W
1795	1	2610lm/23W	3650lm/32W
2470	2	3480lm/30W	4870lm/43W
2860	2	4180lm/37W	5840lm/51W

L mm	Lenghts	Lumen/Watt Low Power	Lumen/Watt Medium Power
1310	1	2280lm/15W	3190lm/21W
1505	1	2740lm/18W	3830lm/25W
1795	1	3420lm/23W	4780lm/32W
2470	2	4560lm/30W	6380lm/43W
2860	2	5470lm/37W	7650lm/51W

Lumen Values: Luminaire luminous flux at 4000K/CRI>80. Other configurations on request.

1- Length



2- Lengths

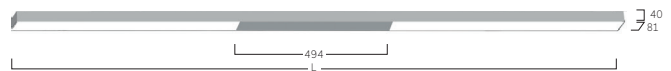

**B** Jet Black  
**W** Snow White



**B** Jet Black  
**F** Anodic Silver



**B** Jet Black  
**D** Anodic Black



**B** Jet Black  
**G** Satin Gold



**B** Jet Black  
**X** Satin Bronze



**B** Jet Black  
**K** Satin Copper



## Midpoint Déco C1/C2 | Track



**DE** LED-Strahler für 3-Phasen-Stromschienen. 350° drehbar und 90° schwenkbar. Rückversetzte sphärische Linse für breitstrahlende Lichtverteilung (70°) und dekorativem konischen Reflektor. Gehäuse-Außenfläche und dekorativer Reflektor in unterschiedlichen Lackierungen und Kombinationen erhältlich, z.B. weiß, silber, graphit, schwarz, gold oder kupferfarben lackiert. Zu Oberflächenoptionen- und Kombinationen siehe Lightnet-Surface-Collection oder Bi-Colour-Auswahl. Linse optional mit Magic Colour Filter für colorierte Lichteffekte. Konverter wahlweise in Leuchtgehäuse oder Stromschiene integriert, einfach schaltbar oder stufenlos dimmbar (DALI, Casambi). Farbtemperatur 2700K, 3000K, 3500K, 4000K, Tunable White oder Dim to Warm. Binning initial  $\leq$  MacAdam 3. Farbwiedergabe CRI $>$ 90. Inklusive Stromschienenadapter.

**EN** LED spotlight for 3-phase tracks. 350° rotation and 90° tilt. Recessed spherical lens for wide-angle light distribution (70°) and decorative conical reflector. Outer housing and decorative reflector available in various finishes and combinations, e.g. white, silver, graphite, black, gold or copper coated. For surface options and combinations, see Lightnet-Surface-Collection or Bi-Colour selection. Lens optionally with Magic Colour Filter for coloured lighting effects. Driver can be integrated into luminaire housing or track, available as switched or dimmable (DALI, Casambi). Colour temperature 2700K, 3000K, 3500K, 4000K, Tunable White or Dim to Warm. Binning  $\leq$  MacAdam 3. Colour rendering CRI $>$ 90. Track adapter included.

**PC2 DWE - 927H - BKB**

Product Family	<b>P:</b> Midpoint Déco
Type	<b>C1:</b> 3-Phase Track [in track electronic], <b>C2:</b> 3-Phase Track [in house electronic]
Beam Angle	<b>D:</b> Lens 70°
Surface Finish	<b>W:</b> Snow White, <b>B:</b> Jet Black, <b>V:</b> Ivory White, <b>D:</b> Anodic Black, <b>F:</b> Anodic Silver, <b>M:</b> Satin Cloud, <b>X:</b> Satin Bronze
Control Gear	<b>E:</b> On/Off, <b>L:</b> DALI, <b>C:</b> Casambi, <b>TW:</b> Tunable White (DT6 only 3-Phase Track in house electronic; DT8)
Colour Rendering	<b>9:</b> CRI>90, <b>8:</b> CRI>80, <b>2:</b> CRI>97, <b>3:</b> CRI>97 (Fashion White), <b>4:</b> CRI>97 (Fashion Colour)
Colour Temperature	<b>27:</b> 2700K, <b>30:</b> 3000K, <b>35:</b> 3500K, <b>40:</b> 4000K, <b>TW:</b> Tunable White 2700-6500K, <b>DW:</b> Dim to warm 3000-1800K
Power	<b>M:</b> Medium Power <b>H:</b> High Power
Cone Surface	<b>W:</b> Snow White, <b>B:</b> Jet Black, <b>D:</b> Anodic Black, <b>F:</b> Anodic Silver, <b>V:</b> Ivory White, <b>M:</b> Satin Cloud, <b>K:</b> Satin Copper, <b>G:</b> Satin Gold, <b>J:</b> Satin Pale Gold, <b>L:</b> Satin Cupria
Lens	<b>K:</b> Clear [Standard], <b>F:</b> Magic Colour Filter
Adaptor	<b>B:</b> Black, <b>W:</b> White



70° Deep Cone Lens

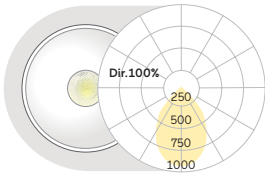

LED	Lumen/Watt Medium Power	Lumen/Watt High Power
4000K	1070lm/14W	1770lm/27W

Lumen Values: Luminaire luminous flux at 4000K/CRI>80. Other configurations on request.

PC1: 3-Phase Track [in track electronic]

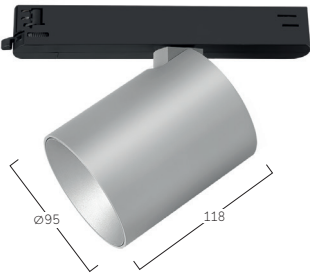

PC2: 3-Phase Track [in house electronic]



Magic Colour Filter



**W** Snow White  
**W** Snow White

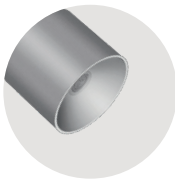

**F** Anodic Silver  
**F** Anodic Silver

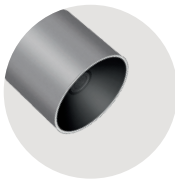

**F** Anodic Silver  
**B** Jet Black

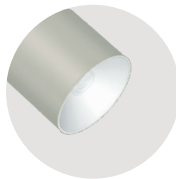

**M** Satin Cloud  
**W** Snow White



**B** Jet Black  
**K** Satin Copper

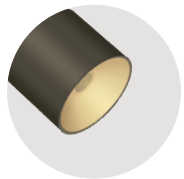

**X** Satin Bronze  
**G** Satin Gold

## Midpoint Anti-Glare C3/C4 | Track



**DE** LED-Strahler für 3-Phasen-Stromschienen. 350° drehbar und 90° schwenkbar. Austauschbare Anti-Glare-Linse für besten Lichtkomfort. Je nach Ausführung auch mit Blendungsbegrenzung (UGR<19) für Office Anwendungen. Höchste Energieeffizienz von bis zu 155lm/W. Ausstrahlwinkel: 15° (Spot), 24° (Medium), 36° (Flood) oder 60° (Wide Flood). Optional ovale Linsen oder Wabenraster. Gehäuse-Außenfläche und dekorativer Linsenring in unterschiedlichen Lackierungen und Kombinationen erhältlich, z.B. weiß, silber, graphit, schwarz, gold oder kupferfarben lackiert. Zu Oberflächenoptionen- und Kombinationen siehe Lightnet-Surface-Collection oder Bi-Colour-Auswahl. Konverter wahlweise in Leuchtengehäuse oder Stromschiene integriert, einfach schaltbar oder stufenlos dimmbar (DALI, Casambi). Farbtemperatur 2700K, 3000K, 3500K, 4000K, Tunable White oder Dim to Warm. Binning initial ≤ MacAdam 3. Farbwiedergabe CRI>80, CRI>90 oder CRI>97 für höchste Lichtqualität. Wahlweise auch Spezialausführungen für White & Colour-Fashion. Inklusive Stromschienenadapter.

**EN** LED spotlight for 3-phase tracks. 350° rotation and 90° tilt. Replaceable anti-glare lens for optimum lighting comfort. Depending on the version, also available with glare reduction (UGR<19) for workplaces. Highest energy efficiency of up to 155lm/W. Beam angle: 15° (Spot), 24° (Medium), 36° (Flood) or 60° (Wide Flood). Optional oval lenses or honeycomb louvre. Outer housing and decorative lens ring available in various finishes and combinations, e.g. white, silver, graphite, black, gold or copper coated. For surface options and combinations, see Lightnet-Surface-Collection or Bi-Colour selection. Driver optionally integrated into luminaire housing or track, optionally switchable or dimmable (DALI, Casambi). Colour temperature 2700K, 3000K, 3500K, 4000K, Tunable White or Dim to Warm. Binning ≤ MacAdam 3. Colour rendering CRI>80, CRI>90 or CRI>97 for maximum light quality. Special versions for white & colour fashion are also available. Track adapter included.

**PC3 BWE - 9 27H-BKB**

Product Family	<b>P:</b> Midpoint
Type	<b>C3:</b> 3-Phase Track [in track electronic], <b>C4:</b> 3-Phase Track [in house electronic]
Beam Angle	<b>A:</b> Anti-Glare Lens 15°, <b>B:</b> Anti-Glare Lens 24°, <b>C:</b> Anti-Glare Lens 36°, <b>F:</b> Anti-Glare Lens 60°, <b>X:</b> Anti-Glare Lens 36°+OVAL <b>Y:</b> Anti-Glare Lens 60°+OVAL
Surface Finish	<b>W:</b> Snow White, <b>B:</b> Jet Black, <b>V:</b> Ivory White, <b>D:</b> Anodic Black, <b>F:</b> Anodic Silver, <b>M:</b> Satin Cloud, <b>X:</b> Satin Bronze
Control Gear	<b>E:</b> On/Off, <b>L:</b> DALI, <b>C:</b> Casambi, <b>TW:</b> Tunable White (DT6 only 3-Phase Track in hous electronic; DT8)
Colour Rendering	<b>9:</b> CRI>90, <b>8:</b> CRI>80, <b>2:</b> CRI>97, <b>3:</b> CRI>97 (Fashion White), <b>4:</b> CRI>97 (Fashion Colour)
Colour Temperature	<b>27:</b> 2700K, <b>30:</b> 3000K, <b>35:</b> 3500K, <b>40:</b> 4000K, <b>TW:</b> Tunable White 2700-6500K, <b>DW:</b> Dim to warm 3000-1800K
Power	<b>M:</b> Medium Power <b>H:</b> High Power
Cone Surface	<b>W:</b> Snow White, <b>B:</b> Jet Black, <b>D:</b> Anodic Black, <b>F:</b> Anodic Silver, <b>V:</b> Ivory White, <b>M:</b> Satin Cloud, <b>K:</b> Satin Copper, <b>G:</b> Satin Gold, <b>J:</b> Satin Pale Gold, <b>L:</b> Satin Cupria
Cover	<b>K:</b> Clear [Standard], <b>H:</b> Honeycomb Louvre
Adaptor	<b>B:</b> Black, <b>W:</b> White



15° Anti-Glare Lens			24° Anti-Glare Lens			36° Anti-Glare Lens			60° Anti-Glare Lens		
<b>LED</b>	<b>Lumen/Watt Medium Power</b>	<b>Lumen/Watt High Power</b>	<b>LED</b>	<b>Lumen/Watt Medium Power</b>	<b>Lumen/Watt High Power</b>	<b>LED</b>	<b>Lumen/Watt Medium Power</b>	<b>Lumen/Watt High Power</b>	<b>LED</b>	<b>Lumen/Watt Medium Power</b>	<b>Lumen/Watt High Power</b>
4000K	2010lm/13W	2930lm/20W	4000K	2050lm/13W	2930lm/20W	4000K	2030lm/13W +OVAL 1920lm/13W	2920lm/20W 2770lm/20W	4000K	2000lm/13W +OVAL 1880lm/13W	2910lm/20W 2700lm/20W

Lumen Values: Luminarie luminous flux at 4000K/CRI>80. Other configurations on request.

**PC3: 3-Phase Track [in track electronic]**

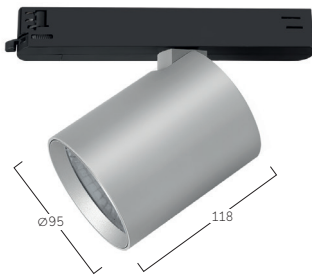

**PC4: 3-Phase Track [in house electronic]**

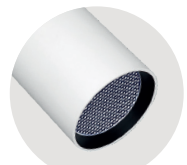

Honeycomb Louvre



## Midpoint Déco W1/W2 | Wall



**DE** LED-Strahler für Wandanbaumontage. Direkt-indirektstrahlend. Rückversetzte sphärische Linse für breitstrahlende Lichtverteilung (70°) und dekorativem konischen Reflektor. Gehäuse-Außenfläche und dekorativer Reflektor in unterschiedlichen Lackierungen und Kombinationen erhältlich, z.B. weiß, silber, graphit, schwarz, gold oder kupferfarben lackiert. Zu Oberflächenoptionen- und Kombinationen siehe Lightnet-Surface-Collection oder Bi-Colour-Auswahl. Linse optional mit Magic Colour Filter für colorierte Lichteffekte. Konverter in Leuchtgehäuse integriert, einfach schaltbar oder stufenlos dimmbar (DALI, TRIAC, Casambi). Farbtemperatur 2700K, 3000K, 3500K, 4000K oder Dim to Warm. Binning initial  $\leq$  MacAdam 3. Farbwiedergabe CRI $>$ 90.

**EN** LED spotlight for wall surface mounting. Direct-indirect light distribution. Recessed spherical lens for wide-angle light distribution (70°) and decorative conical reflector. Outer housing and decorative reflector available in various finishes and combinations, e.g. white, silver, graphite, black, gold or copper coated. For surface options and combinations, see Lightnet-Surface-Collection or Bi-Colour selection. Lens optionally with Magic Colour Filter for coloured lighting effects. Driver integrated into luminaire housing, available as switched or dimmable (DALI, TRIAC, Casambi). Colour temperature 2700K, 3000K, 3500K, 4000K or Dim to Warm. Binnings  $\leq$  MacAdam 3. Colour rendering CRI $>$ 90.

**PW2DWE-9 27M-BK**

Product Family	<b>P:</b> Midpoint Déco
Type	<b>W1:</b> Direct, <b>W2:</b> Direct-Indirect
Beam Angle	<b>D:</b> Lens 70°
Surface Finish	<b>W:</b> Snow White, <b>B:</b> Jet Black, <b>V:</b> Ivory White, <b>D:</b> Anodic Black, <b>F:</b> Anodic Silver, <b>M:</b> Satin Cloud, <b>X:</b> Satin Bronze
Control Gear	<b>E:</b> On/Off, <b>L:</b> DALI, <b>C:</b> Casambi, <b>P:</b> Triac Dimming
Colour Rendering	<b>9:</b> CRI>90, <b>8:</b> CRI>80, <b>2:</b> CRI>97
Colour Temperature	<b>27:</b> 2700K, <b>30:</b> 3000K, <b>35:</b> 3500K, <b>40:</b> 4000K, <b>DW:</b> Dim to warm 3000-1800K
Power	<b>M:</b> Medium Power <b>H:</b> High Power
Cone Surface	<b>W:</b> Snow White, <b>B:</b> Jet Black, <b>D:</b> Anodic Black, <b>F:</b> Anodic Silver, <b>V:</b> Ivory White, <b>M:</b> Satin Cloud, <b>K:</b> Satin Copper, <b>G:</b> Satin Gold, <b>J:</b> Satin Pale Gold, <b>L:</b> Satin Cupria
Cover	<b>K:</b> Clear [Standard], <b>F:</b> Magic Colour Filter

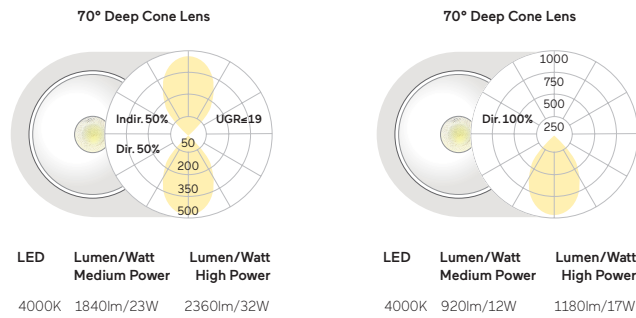

Lumen Values: Luminaire luminous flux at 4000K/CRI>80. Other configurations on request.

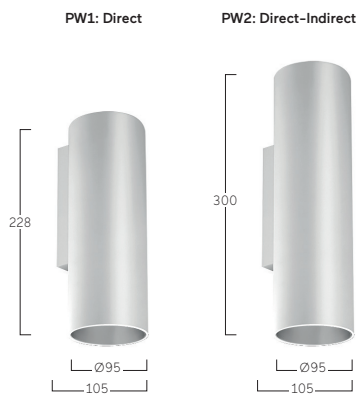

## Midpoint Anti-Glare W3/W4 | Wall



**DE** LED-Strahler für Wandanbaumontage. Direkt-indirektstrahlend. Austauschbare Anti-Glare-Linse für besten Lichtkomfort. Je nach Ausführung auch mit Blendungsbegrenzung (UGR<19) für Office Anwendungen. Höchste Energieeffizienz von bis zu 155lm/W. Ausstrahlwinkel: 15° (Spot), 24° (Medium), 36° (Flood) oder 60° (Wide Flood). Optional Ovale Linsen oder Wabenraster. Gehäuse-Außenfläche und dekorativer Linsenring in unterschiedlichen Lackierungen und Kombinationen erhältlich, z.B. weiß, silber, graphit, schwarz, gold oder kupferfarben lackiert. Zu Oberflächenoptionen- und Kombinationen siehe Lightnet-Surface-Collection oder Bi-Colour-Auswahl. Konverter wahlweise in Leuchtengehäuse oder Stromschiene integriert, einfach schaltbar oder stufenlos dimmbar (DALI, Casambi). Farbtemperatur 2700K, 3000K, 3500K, 4000K oder Dim to Warm. Binning initial  $\leq$  MacAdam 3. Farbwiedergabe CRI>80, CRI>90 oder CRI>97 für höchste Lichtqualität. Wahlweise auch Spezialausführungen für White & Colour-Fashion.

**EN** LED spotlight for wall surface mounting. Direct-indirect light distribution. Replaceable anti-glare lens for optimum lighting comfort. Depending on the version, also available with glare reduction (UGR<19) for workplaces. Highest energy efficiency of up to 155lm/W. Beam angle: 15° (Spot), 24° (Medium), 36° (Flood) or 60° (Wide Flood). Optional oval lenses or honeycomb louvre. Outer housing and decorative lens ring available in various finishes and combinations, e.g. white, silver, graphite, black, gold or copper coated. For surface options and combinations, see Lightnet-Surface-Collection or Bi-Colour selection. Driver optionally integrated into luminaire housing or track, available as switched or dimmable (DALI, Casambi). Colour temperature 2700K, 3000K, 3500K, 4000K or Dim to Warm. Binning  $\leq$  MacAdam 3. Colour rendering CRI>80, CRI>90 or CRI>97 for maximum light quality. Special versions for white & colour fashion are also available.

**P W3 B W E - 9 27 H - B K**

Product Family	<b>P:</b> Midpoint
Type	<b>W3:</b> Direct, <b>W4:</b> Direct-Indirect
Beam Angle	<b>A:</b> Anti-Glare Lens 15°, <b>B:</b> Anti-Glare Lens 24°, <b>C:</b> Anti-Glare Lens 36°, <b>F:</b> Anti-Glare Lens 60°
Surface Finish	<b>W:</b> Snow White, <b>B:</b> Jet Black, <b>V:</b> Ivory White, <b>D:</b> Anodic Black, <b>F:</b> Anodic Silver, <b>M:</b> Satin Cloud, <b>X:</b> Satin Bronze
Control Gear	<b>E:</b> On/Off, <b>L:</b> DALI, <b>C:</b> Casambi, <b>P:</b> Triac Dimming
Colour Rendering	<b>9:</b> CRI>90, <b>8:</b> CRI>80, <b>2:</b> CRI>97
Colour Temperature	<b>27:</b> 2700K, <b>30:</b> 3000K, <b>35:</b> 3500K, <b>40:</b> 4000K, <b>DW:</b> Dim to warm 3000-1800K
Power	<b>M:</b> Medium Power <b>H:</b> High Power
Cone Surface	<b>W:</b> Snow White, <b>B:</b> Jet Black, <b>D:</b> Anodic Black, <b>F:</b> Anodic Silver, <b>V:</b> Ivory White, <b>M:</b> Satin Cloud, <b>K:</b> Satin Copper, <b>G:</b> Satin Gold, <b>J:</b> Satin Pale Gold, <b>L:</b> Satin Cupria
Cover	<b>K:</b> Clear [Standard]

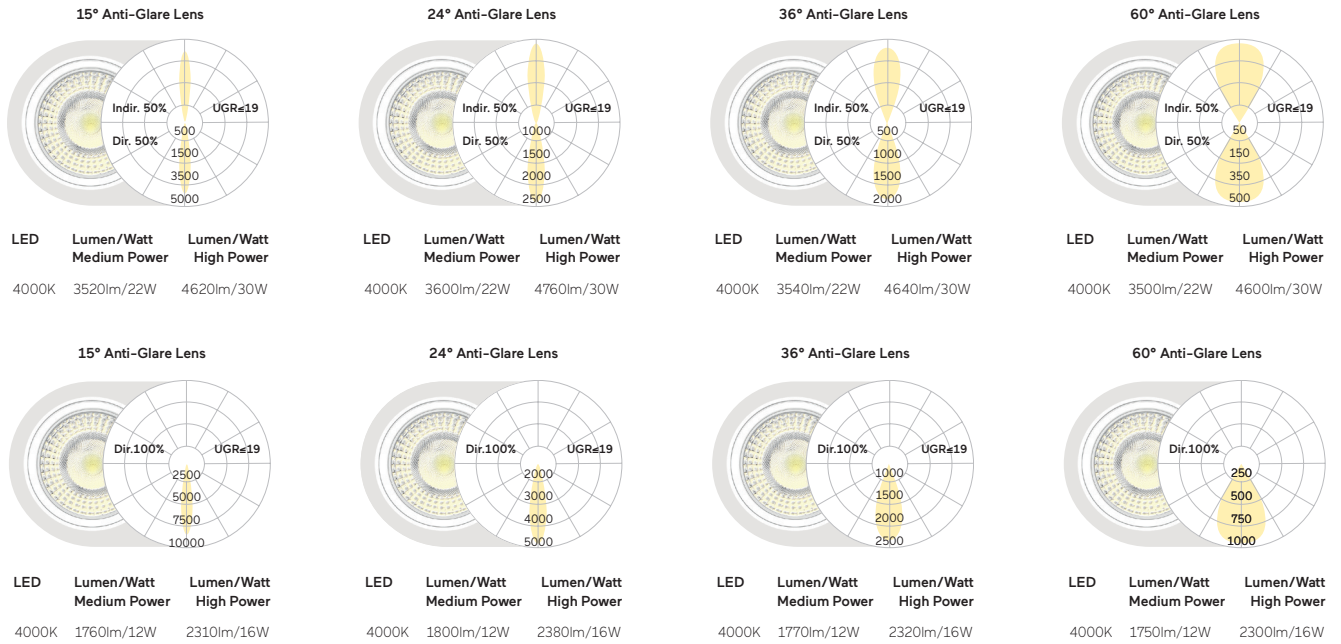

Lumen Values: Luminaire luminous flux at 4000K/CRI>80. Other configurations on request.





## Midpoint Déco P1 | Suspended



**DE** LED-Strahler für Pendelmontage. Direktstrahlend. Rückversetzte sphärische Linse für breitstrahlende Lichtverteilung (70°) und dekorativem konischen Reflektor. Gehäuse-Außenfläche und dekorativer Reflektor in unterschiedlichen Lackierungen und Kombinationen erhältlich, z.B. weiß, silber, graphit, schwarz, gold oder kupferfarben lackiert. Zu Oberflächenoptionen- und Kombinationen siehe Lightnet-Surface-Collection oder Bi-Colour-Auswahl. Linse optional mit Magic Colour Filter für colorierte Lichteffekte. Konverter in Leuchtgehäuse integriert, einfach schaltbar oder stufenlos dimmbar (DALI, TRIAC, Casambi). Farbtemperatur 2700K, 3000K, 3500K, 4000K, Tunable White oder Dim to Warm. Binning initial  $\leq$  MacAdam 3. Farbwiedergabe CRI $>$ 90. Zuleitungskabel wahlweise transparent, rot oder schwarz.

**EN** LED spotlight for pendant mounting. Direct-only light distribution. Recessed spherical lens for wide-angle light distribution (70°) and decorative conical reflector. Outer housing and decorative reflector available in various finishes and combinations, e.g. white, silver, graphite, black, gold or copper coated. For surface options and combinations, see Lightnet-Surface-Collection or Bi-Colour selection. Lens optionally with Magic Colour Filter for coloured lighting effects. Driver integrated into luminaire housing, available as switched or dimmable (DALI, TRIAC, Casambi). Colour temperature 2700K, 3000K, 3500K, 4000K, Tunable White or Dim to Warm. Binning  $\leq$  MacAdam 3. Colour rendering CRI $>$ 90. Optional transparent, red or black power supply cable.

**PP1DBE-9 27 M-L210-WK-T**

Product Family	<b>P:</b> Midpoint Déco
Type	<b>P1:</b> Direct
Beam Angle	<b>D:</b> Lens 70°
Surface Finish	<b>W:</b> Snow White, <b>B:</b> Jet Black, <b>V:</b> Ivory White, <b>D:</b> Anodic Black, <b>F:</b> Anodic Silver, <b>M:</b> Satin Cloud, <b>X:</b> Satin Bronze
Control Gear	<b>E:</b> On/Off, <b>L:</b> DALI, <b>C:</b> Casambi, <b>TW:</b> Tunable White (DT6 or DT8), <b>P:</b> Triac Dimming
Colour Rendering	<b>9:</b> CRI>90, <b>8:</b> CRI>80, <b>2:</b> CRI>97, <b>3:</b> CRI>97 (Fashion White), <b>4:</b> CRI>97 (Fashion Colour)
Colour Temperature	<b>27:</b> 2700K, <b>30:</b> 3000K, <b>35:</b> 3500K, <b>40:</b> 4000K, <b>TW:</b> Tunable White 2700-6500K, <b>DW:</b> Dim to warm 3000-1800K
Power	<b>M:</b> Medium Power <b>H:</b> High Power
Size	Luminaire Length in mm: <b>L210, L500, L800</b>
Cone Surface	<b>W:</b> Snow White, <b>B:</b> Jet Black, <b>D:</b> Anodic Black, <b>F:</b> Anodic Silver, <b>V:</b> Ivory White, <b>M:</b> Satin Cloud, <b>K:</b> Satin Copper, <b>G:</b> Satin Gold, <b>J:</b> Satin Pale Gold, <b>L:</b> Satin Cupria
Lens	<b>K:</b> Clear [Standard], <b>F:</b> Magic Colour Filter
Cable Colour	<b>T:</b> Transparent, <b>R:</b> Red, <b>B:</b> Black



**70° Deep Cone Lens**

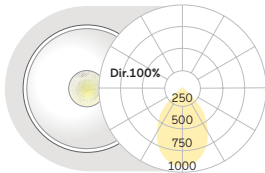

LED	Lumen/Watt Medium Power	Lumen/Watt High Power
4000K	1070lm/14W	1770lm/27W

Lumen Values: Luminaire luminous flux at 4000K/CRI>80. Other configurations on request.

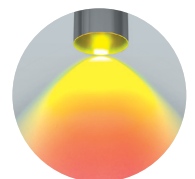
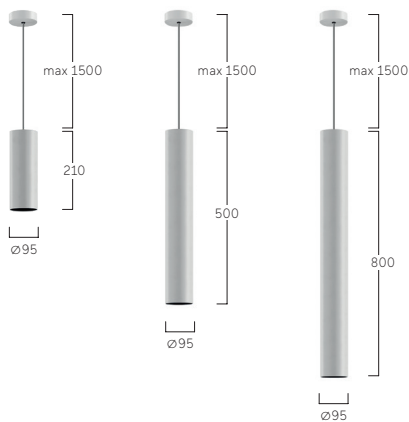

Magic Colour Filter



**W** Snow White  
**W** Snow White



**F** Anodic Silver  
**F** Anodic Silver



**F** Anodic Silver  
**B** Jet Black



**M** Satin Cloud  
**M** Satin Cloud



**B** Jet Black  
**K** Satin Copper



**X** Satin Bronze  
**G** Satin Gold

## Midpoint Anti-Glare P3 | Suspended



**DE** LED-Strahler für Pendelmontage. Direktstrahlend. Austauschbare Anti-Glare-Linse für besten Lichtkomfort. Je nach Ausführung auch mit Blendungsbegrenzung (UGR<19) für Office Anwendungen. Höchste Energieeffizienz von bis zu 155lm/W. Ausstrahlwinkel: 15° (Spot), 24° (Medium), 36° (Flood) oder 60° (Wide Flood). Optional ovale Linsen oder Wabenraster. Gehäuse-Außenfläche und dekorativer Linserring in unterschiedlichen Lackierungen und Kombinationen erhältlich, z.B. weiß, silber, graphit, schwarz, gold oder kupferfarben lackiert. Zu Oberflächenoptionen- und Kombinationen siehe Lightnet-Surface-Collection oder Bi-Colour-Auswahl. Konverter in Leuchtgehäuse integriert, einfach schaltbar oder stufenlos dimmbar (DALI, Casambi). Farbtemperatur 2700K, 3000K, 3500K, 4000K, Tunable White oder Dim to Warm. Binning initial  $\leq$  MacAdam 3. Farbwiedergabe CRI>80, CRI>90 oder CRI>97 für höchste Lichtqualität. Wahlweise auch Spezialausführungen für White & Colour-Fashion. Zuleitungskabel wahlweise transparent, rot oder schwarz.

**EN** LED spotlight for pendant mounting. Direct-only light distribution. Replaceable anti-glare lens for optimum lighting comfort. Depending on the version, also available with glare reduction (UGR<19) for workplaces. Highest energy efficiency of up to 155lm/W. Beam angle: 15° (Spot), 24° (Medium), 36° (Flood) or 60° (Wide Flood). Optional oval lenses or honeycomb louvre. Outer housing and decorative lens ring available in various finishes and combinations, e.g. white, silver, graphite, black, gold or copper coated. For surface options and combinations, see Lightnet-Surface-Collection or Bi-Colour selection. Driver integrated into luminaire housing, available as switched or dimmable (DALI, Casambi). Colour temperature 2700K, 3000K, 3500K, 4000K, Tunable White or Dim to Warm. Binning  $\leq$  MacAdam 3. Colour rendering CRI>80, CRI>90 or CRI>97 for maximum light quality. Special versions for white & colour fashion are also available. Optional transparent, red or black power supply cable.

**PP3ABE-927M-L210-WK-T**

Product Family	<b>P:</b> Midpoint
Type	<b>P3:</b> Direct
Beam Angle	<b>A:</b> Anti-Glare Lens 15°, <b>B:</b> Anti-Glare Lens 24°, <b>C:</b> Anti-Glare Lens 36°, <b>F:</b> Anti-Glare Lens 60°, <b>X:</b> Anti-Glare Lens 36°+OVAL <b>Y:</b> Anti-Glare Lens 60°+OVAL
Surface Finish	<b>W:</b> Snow White, <b>B:</b> Jet Black, <b>V:</b> Ivory White, <b>D:</b> Anodic Black, <b>F:</b> Anodic Silver, <b>M:</b> Satin Cloud, <b>X:</b> Satin Bronze
Control Gear	<b>E:</b> On/Off, <b>L:</b> DALI, <b>C:</b> Casambi, <b>TW:</b> Tunable White (DT6 or DT8), <b>P:</b> Triac Dimming
Colour Rendering	<b>9:</b> CRI>90, <b>8:</b> CRI>80, <b>2:</b> CRI>97, <b>3:</b> CRI>97 (Fashion White), <b>4:</b> CRI>97 (Fashion Colour)
Colour Temperature	<b>27:</b> 2700K, <b>30:</b> 3000K, <b>35:</b> 3500K, <b>40:</b> 4000K, <b>TW:</b> Tunable White 2700-6500K, <b>DW:</b> Dim to warm 3000-1800K
Power	<b>M:</b> Medium Power <b>H:</b> High Power
Size	Luminaire Length in mm: <b>L210, L500, L800</b>
Cone Surface	<b>W:</b> Snow White, <b>B:</b> Jet Black, <b>D:</b> Anodic Black, <b>F:</b> Anodic Silver, <b>V:</b> Ivory White, <b>M:</b> Satin Cloud, <b>K:</b> Satin Copper, <b>G:</b> Satin Gold, <b>J:</b> Satin Pale Gold, <b>L:</b> Satin Cupria
Cover	<b>K:</b> Clear [Standard], <b>H:</b> Honeycomb Louvre
Cable Colour	<b>T:</b> Transparent, <b>R:</b> Red, <b>B:</b> Black



15° Anti-Glare Lens			24° Anti-Glare Lens			36° Anti-Glare Lens			60° Anti-Glare Lens		
<b>LED</b>	<b>Lumen/Watt Medium Power</b>	<b>Lumen/Watt High Power</b>	<b>LED</b>	<b>Lumen/Watt Medium Power</b>	<b>Lumen/Watt High Power</b>	<b>LED</b>	<b>Lumen/Watt Medium Power</b>	<b>Lumen/Watt High Power</b>	<b>LED</b>	<b>Lumen/Watt Medium Power</b>	<b>Lumen/Watt High Power</b>
4000K	2010lm/13W	2930lm/20W	4000K	2050lm/13W	2930lm/20W	4000K	2030lm/13W +OVAL 1920lm/13W	2920lm/20W 2770lm/20W	4000K	2000lm/13W +OVAL 1880lm/13W	2910lm/20W 2700lm/20W

Lumen Values: Luminaire luminous flux at 4000K/CRI>80. Other configurations on request.

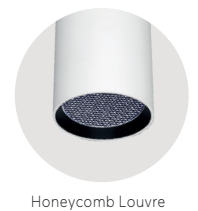
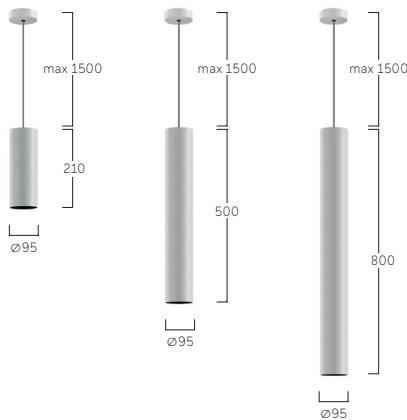

## Midpoint Déco A1/A2 | Surface



**DE** LED-Strahler für Anbaumontage. Direktstrahlend. Rückversetzte sphärische Linse für breitstrahlende Lichtverteilung (70°) und dekorativem konischen Reflektor. Gehäuse-Außenfläche und dekorativer Reflektor in unterschiedlichen Lackierungen und Kombinationen erhältlich, z.B. weiß, silber, graphit, schwarz, gold oder kupferfarben lackiert. Zu Oberflächenoptionen- und Kombinationen siehe Lightnet-Surface-Collection oder Bi-Colour-Auswahl. Linse optional mit Magic Colour Filter für colorierte Lichteffekte. Konverter in Leuchtgehäuse integriert, einfach schaltbar oder stufenlos dimmbar (DALI, TRIAC, Casambi). Farbtemperatur 2700K, 3000K, 3500K, 4000K, Tunable White oder Dim to Warm. Binning initial  $\leq$  MacAdam 3. Farbwiedergabe CRI>90.

**EN** LED surface-mounted spotlight. Direct-only light distribution. Recessed spherical lens for wide-angle light distribution (70°) and decorative conical reflector. Outer housing and decorative reflector available in various finishes and combinations, e.g. white, silver, graphite, black, gold or copper coated. For surface options and combinations, see Lightnet-Surface-Collection or Bi-Colour selection. Lens optionally with Magic Colour Filter for coloured lighting effects. Driver integrated into luminaires housing, available as switched or dimmable (DALI, TRIAC, Casambi). Colour temperature 2700K, 3000K, 3500K, 4000K, Tunable White or Dim to Warm. Binning  $\leq$  MacAdam 3. Colour rendering CRI>90.

**PA1 D B E - 9 27 M - WK**

Product Family	<b>P:</b> Midpoint Déco
Type	<b>A1:</b> Direct Fix , <b>A2:</b> Direct Rotatable-Twistable
Beam Angle	<b>D:</b> Lens 70°
Surface Finish	<b>W:</b> Snow White, <b>B:</b> Jet Black, <b>V:</b> Ivory White, <b>D:</b> Anodic Black, <b>F:</b> Anodic Silver, <b>M:</b> Satin Cloud, <b>X:</b> Satin Bronze
Control Gear	<b>E:</b> On/Off, <b>L:</b> DALI, <b>C:</b> Casambi, <b>P:</b> Triac Dimming
Colour Rendering	<b>9:</b> CRI>90, <b>8:</b> CRI>80, <b>2:</b> CRI>97, <b>3:</b> CRI>97 (Fashion White), <b>4:</b> CRI>97 (Fashion Colour)
Colour Temperature	<b>27:</b> 2700K, <b>30:</b> 3000K, <b>35:</b> 3500K, <b>40:</b> 4000K, <b>DW:</b> Dim to warm 3000-1800K
Power	<b>M:</b> Medium Power <b>H:</b> High Power
Cone Surface	<b>W:</b> Snow White, <b>B:</b> Jet Black, <b>D:</b> Anodic Black, <b>F:</b> Anodic Silver, <b>V:</b> Ivory White, <b>M:</b> Satin Cloud, <b>K:</b> Satin Copper, <b>G:</b> Satin Gold, <b>J:</b> Satin Pale Gold, <b>L:</b> Satin Cupria
Lens	<b>K:</b> Clear [Standard], <b>F:</b> Magic Colour Filter



**70° Deep Cone Lens**

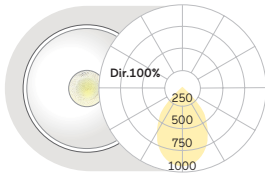

LED	Lumen/Watt Medium Power	Lumen/Watt High Power
4000K	1070lm/14W	1770lm/27W

Lumen Values: Luminaire luminous flux at 4000K/CRI>80. Other configurations on request.

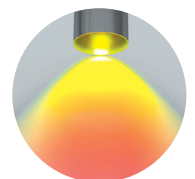
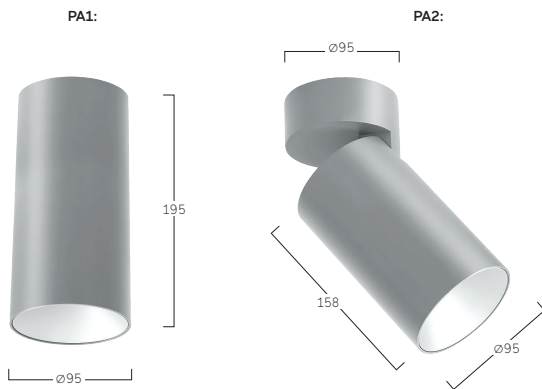

Magic Colour Filter



**W** Snow White  
**W** Snow White



**F** Anodic Silver  
**F** Anodic Silver

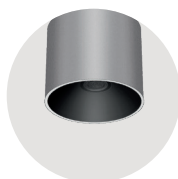

**F** Anodic Silver  
**B** Jet Black



**M** Satin Cloud  
**M** Satin Cloud



**B** Jet Black  
**K** Satin Copper

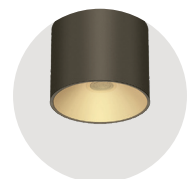

**X** Satin Bronze  
**G** Satin Gold

## Midpoint Anti-Glare A3/A4 | Surface



**DE** LED-Strahler für Anbaumontage. Direktstrahlend. Austauschbare Anti-Glare-Linse für besten Lichtkomfort. Je nach Ausführung auch mit Blendungsbegrenzung (UGR<19) für Office Anwendungen. Höchste Energieeffizienz von bis zu 155lm/W. Ausstrahlwinkel: 15° (Spot), 24° (Medium), 36° (Flood) oder 60° (Wide Flood). Optional ovale Linsen oder Wabenraster. Gehäuse-Außenfläche und dekorativer Linsenring in unterschiedlichen Lackierungen und Kombinationen erhältlich, z.B. weiß, silber, graphit, schwarz, gold oder kupferfarben lackiert. Zu Oberflächenoptionen- und Kombinationen siehe Lightnet-Surface-Collection oder Bi-Colour-Auswahl. Konverter in Leuchtgehäuse integriert, einfach schaltbar oder stufenlos dimmbar (DALI, Casambi). Farbtemperatur 2700K, 3000K, 3500K, 4000K, Tunable White oder Dim to Warm. Binning initial  $\leq$  MacAdam 3. Farbwiedergabe CRI>80, CRI>90 oder CRI>97 für höchste Lichtqualität. Wahlweise auch Spezialausführungen für White & Colour-Fashion.

**EN** LED surface-mounted spotlight. Direct-only light distribution. Replaceable anti-glare lens for optimum lighting comfort. Depending on the version, also available with glare reduction (UGR<19) for workplaces. Highest energy efficiency of up to 155lm/W. Beam angle: 15° (Spot), 24° (Medium), 36° (Flood) or 60° (Wide Flood). Optional oval lenses or honeycomb louvre. Outer housing and decorative lens ring available in various finishes and combinations, e.g. white, silver, graphite, black, gold or copper coated. For surface options and combinations, see Lightnet-Surface-Collection or Bi-Colour selection. Driver integrated into luminaire housing, available as switched or dimmable (DALI, Casambi). Colour temperature 2700K, 3000K, 3500K, 4000K, Tunable White or Dim to Warm. Binning  $\leq$  MacAdam 3. Colour rendering CRI>80, CRI>90 or CRI>97 for maximum light quality. Special versions for white & colour fashion are also available.

**PA3 BWE - 927H-BK**

Product Family	<b>P:</b> Midpoint
Type	<b>A3:</b> Direct Fix, <b>A4:</b> Direct Rotatable-Twistable
Beam Angle	<b>A:</b> Anti-Glare Lens 15°, <b>B:</b> Anti-Glare Lens 24°, <b>C:</b> Anti-Glare Lens 36°, <b>F:</b> Anti-Glare Lens 60°, <b>X:</b> Anti-Glare Lens 36°+OVAL <b>Y:</b> Anti-Glare Lens 60°+OVAL
Surface Finish	<b>W:</b> Snow White, <b>B:</b> Jet Black, <b>V:</b> Ivory White, <b>D:</b> Anodic Black, <b>F:</b> Anodic Silver, <b>M:</b> Satin Cloud, <b>X:</b> Satin Bronze
Control Gear	<b>E:</b> On/Off, <b>L:</b> DALI, <b>C:</b> Casambi, <b>P:</b> Triac Dimming
Colour Rendering	<b>9:</b> CRI>90, <b>8:</b> CRI>80, <b>2:</b> CRI>97, <b>3:</b> CRI>97 (Fashion White), <b>4:</b> CRI>97 (Fashion Colour)
Colour Temperature	<b>27:</b> 2700K, <b>30:</b> 3000K, <b>35:</b> 3500K, <b>40:</b> 4000K, <b>DW:</b> Dim to warm 3000-1800K
Power	<b>M:</b> Medium Power <b>H:</b> High Power
Cone Surface	<b>W:</b> Snow White, <b>B:</b> Jet Black, <b>D:</b> Anodic Black, <b>F:</b> Anodic Silver, <b>V:</b> Ivory White, <b>M:</b> Satin Cloud, <b>K:</b> Satin Copper, <b>G:</b> Satin Gold, <b>J:</b> Satin Pale Gold, <b>L:</b> Satin Cupria
Cover	<b>K:</b> Clear [Standard], <b>H:</b> Honeycomb Louvre



15° Anti-Glare Lens			24° Anti-Glare Lens			36° Anti-Glare Lens			60° Anti-Glare Lens		
<b>LED</b>	<b>Lumen/Watt Medium Power</b>	<b>Lumen/Watt High Power</b>	<b>LED</b>	<b>Lumen/Watt Medium Power</b>	<b>Lumen/Watt High Power</b>	<b>LED</b>	<b>Lumen/Watt Medium Power</b>	<b>Lumen/Watt High Power</b>	<b>LED</b>	<b>Lumen/Watt Medium Power</b>	<b>Lumen/Watt High Power</b>
4000K	2010lm/13W	2930lm/20W	4000K	2050lm/13W	2930lm/20W	4000K	2030lm/13W +OVAL 1920lm/13W	2920lm/20W 2770lm/20W	4000K	2000lm/13W +OVAL 1880lm/13W	2910lm/20W 2700lm/20W

Lumen Values: Luminaire luminous flux at 4000K/CRI>80. Other configurations on request.

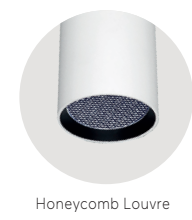
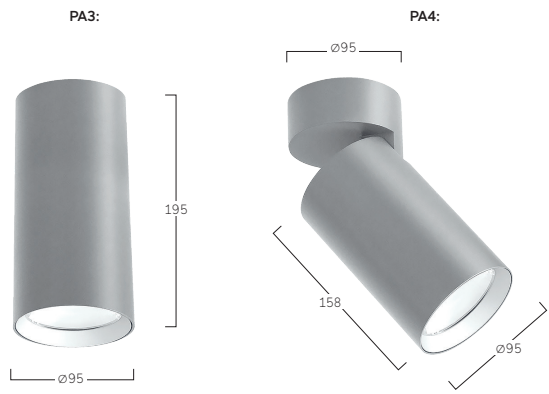



## Midpoint Déco F1/F2 | Recessed

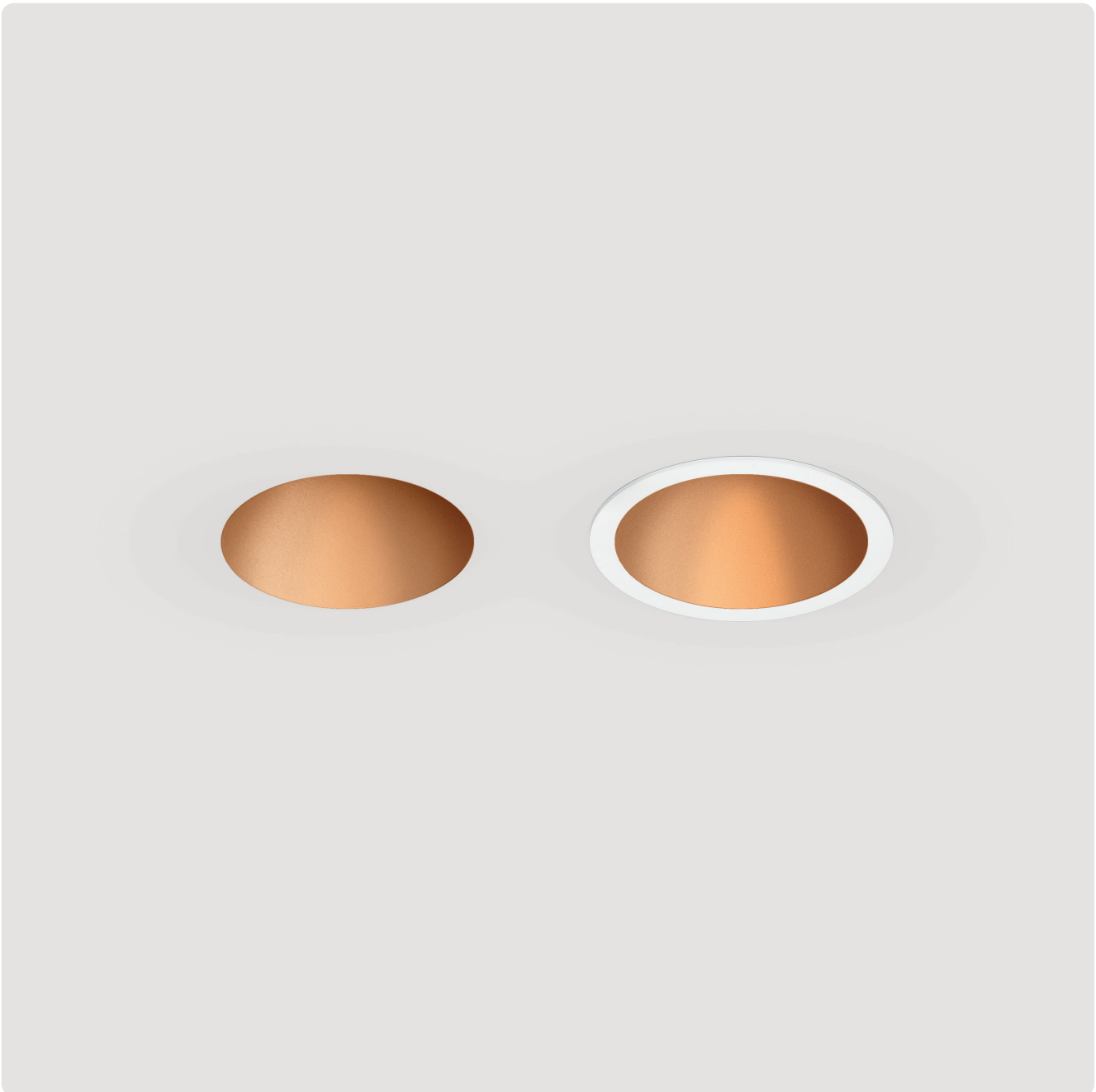

**DE** LED-Strahler für Einbaumontage in gesägten Deckenöffnungen. Separater Konverter im Lieferumfang enthalten, wahlweise einfach schaltbar oder stufenlos dimmbar (DALI, TRIAC, Casambi). Rückversetzte sphärische Linse für breitstrahlende Lichtverteilung (70°) und dekorativem konischen Reflektor. Gehäuse-Außenfläche und dekorativer Reflektor in unterschiedlichen Lackierungen und Kombinationen erhältlich, z.B. weiß, silber, graphit, schwarz, gold oder kupferfarben lackiert. Zu Oberflächenoptionen- und Kombinationen siehe Lightnet-Surface-Collection oder Bi-Colour-Auswahl. Linse optional mit Magic Colour Filter für colorierte Lichteffekte. Farbtemperatur 2700K, 3000K, 3500K, 4000K, Tunable White oder Dim to Warm. Binning initial  $\leq$  MacAdam 3. Farbwiedergabe CRI $>$ 90.

**EN** LED recessed spotlight for installation in ceiling cut-outs openings. Separate driver included, with options of switched or dimmable (DALI, TRIAC, Casambi). Recessed spherical lens for wide-angle light distribution (70°) and decorative conical reflector. Outer housing and decorative reflector available in various finishes and combinations, e.g. white, silver, graphite, black, gold or copper coated. For surface options and combinations, see Lightnet-Surface-Collection or Bi-Colour selection. Lens optionally with Magic Colour Filter for coloured lighting effects. Colour temperature 2700K, 3000K, 3500K, 4000K, Tunable White or Dim to Warm. Binning  $\leq$  MacAdam 3. Colour rendering CRI $>$ 90.

**P F2 D B E - 9 27 M - B K**

Product Family	<b>P:</b> Midpoint
Type	<b>F1:</b> Frame, <b>F2:</b> Frameless
Beam Angle	<b>D:</b> Lens 70°
Surface Finish	<b>W:</b> Snow White, <b>B:</b> Jet Black, <b>V:</b> Ivory White, <b>D:</b> Anodic Black, <b>F:</b> Anodic Silver, <b>M:</b> Satin Cloud, <b>X:</b> Satin Bronze
Control Gear	<b>E:</b> On/Off, <b>L:</b> DALI, <b>C:</b> Casambi, <b>P:</b> Triac Dimming
Colour Rendering	<b>9:</b> CRI>90, <b>8:</b> CRI>80, <b>2:</b> CRI>97, <b>3:</b> CRI>97 (Fashion White), <b>4:</b> CRI>97 (Fashion Colour)
Colour Temperature	<b>27:</b> 2700K, <b>30:</b> 3000K, <b>35:</b> 3500K, <b>40:</b> 4000K, <b>DW:</b> Dim to warm 3000-1800K
Power	<b>M:</b> Medium Power, <b>H:</b> High Power
Colour Surface	<b>W:</b> Snow White, <b>B:</b> Jet Black, <b>D:</b> Anodic Black, <b>F:</b> Anodic Silver, <b>V:</b> Ivory White, <b>M:</b> Satin Cloud, <b>K:</b> Satin Copper, <b>G:</b> Satin Gold, <b>J:</b> Satin Pale Gold, <b>L:</b> Satin Cupria
Cover	<b>K:</b> Clear [Standard], <b>F:</b> Magic Colour Filter



**70° Deep Cone Lens**

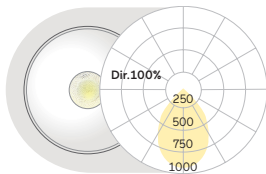

LED	Lumen/Watt Medium Power	Lumen/Watt High Power
4000K	1070lm/14W	1770lm/27W

Lumen Values: Luminaire luminous flux at 4000K/CRI>80. Other configurations on request.

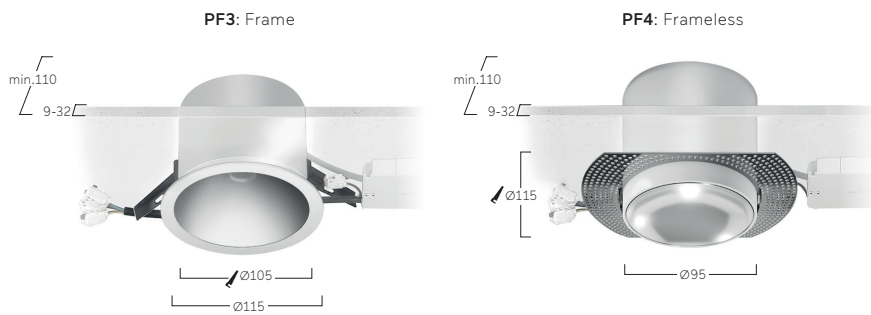

## Midpoint Anti-Glare F3/F4 | Recessed



**DE** LED-Strahler für Einbaumontage in gesägten Deckenöffnungen. Separater Konverter im Lieferumfang enthalten, wahlweise einfach schaltbar oder stufenlos dimmbar (DALI, Casambi). Austauschbare Anti-Glare-Linse für besten Lichtkomfort. Je nach Ausführung auch mit Blendungsbegrenzung (UGR<19) für Office Anwendungen. Höchste Energieeffizienz von bis zu 155lm/W. Ausstrahlwinkel: 15° (Spot), 24° (Medium), 36° (Flood) oder 60° (Wide Flood). Optional ovale Linsen oder Wabenraster. Gehäuse-Außenfläche und dekorativer Linsenring in unterschiedlichen Lackierungen und Kombinationen erhältlich, z.B. weiß, silber, graphit, schwarz, gold oder kupferfarben lackiert. Zu Oberflächenoptionen- und Kombinationen siehe Lightnet-Surface-Collection oder Bi-Colour-Auswahl. Farbtemperatur 2700K, 3000K, 3500K, 4000K, Tunable White oder Dim to Warm. Binning initial  $\leq$  MacAdam 3. Farbwiedergabe CRI>80, CRI>90 oder CRI>97 für höchste Lichtqualität. Wahlweise auch Spezialausführungen für White & Colour-Fashion. Zuleitungskabel wahlweise transparent, rot oder schwarz.

**EN** LED recessed spotlight for installation in ceiling cut-outs openings. Separate driver included, with option of switched or dimmable (DALI, Casambi). Replaceable anti-glare lens for optimum lighting comfort. Depending on the version, also available with glare reduction (UGR<19) for workplaces. Highest energy efficiency of up to 155lm/W. Beam angle: 15° (Spot), 24° (Medium), 36° (Flood) or 60° (Wide Flood). Optional oval lenses or honeycomb louvre. Outer housing and decorative lens ring available in various finishes and combinations, e.g. white, silver, graphite, black, gold or copper coated. For surface options and combinations, see Lightnet-Surface-Collection or Bi-Colour selection. Colour temperature 2700K, 3000K, 3500K, 4000K, Tunable White or Dim to Warm. Binning  $\leq$  MacAdam 3. Colour rendering CRI>80, CRI>90 or CRI>97 for maximum light quality. Special versions for white & colour fashion are also available. Optional transparent, red or black power supply cable.

**P F3 F B E - 9 27 M - B K**

Product Family	<b>P:</b> Midpoint
Type	<b>F3:</b> Frame, <b>F4:</b> Frameless
Beam Angle	<b>A:</b> Anti-Glare Lens 15°, <b>B:</b> Anti-Glare Lens 24°, <b>C:</b> Anti-Glare Lens 36°, <b>F:</b> Anti-Glare Lens 60°, <b>X:</b> Anti-Glare Lens 36°+OVAL <b>Y:</b> Anti-Glare Lens 60°+OVAL
Surface Finish	<b>W:</b> Snow White, <b>B:</b> Jet Black, <b>V:</b> Ivory White, <b>D:</b> Anodic Black, <b>F:</b> Anodic Silver, <b>M:</b> Satin Cloud, <b>X:</b> Satin Bronze
Control Gear	<b>E:</b> On/Off, <b>L:</b> DALI, <b>C:</b> Casambi, <b>P:</b> Triac Dimming
Colour Rendering	<b>9:</b> CRI>90, <b>8:</b> CRI>80, <b>2:</b> CRI>97, <b>3:</b> CRI>97 (Fashion White), <b>4:</b> CRI>97 (Fashion Colour)
Colour Temperature	<b>27:</b> 2700K, <b>30:</b> 3000K, <b>35:</b> 3500K, <b>40:</b> 4000K, <b>DW:</b> Dim to warm 3000-1800K
Power	<b>M:</b> Medium Power, <b>H:</b> High Power
Cone Surface	<b>W:</b> Snow White, <b>B:</b> Jet Black, <b>D:</b> Anodic Black, <b>F:</b> Anodic Silver, <b>V:</b> Ivory White, <b>M:</b> Satin Cloud, <b>K:</b> Satin Copper, <b>G:</b> Satin Gold, <b>J:</b> Satin Pale Gold, <b>L:</b> Satin Cupria
Cover	<b>K:</b> Clear [Standard], <b>H:</b> Honeycomb Louvre



15° Anti-Glare Lens			24° Anti-Glare Lens			36° Anti-Glare Lens			60° Anti-Glare Lens		
<b>LED</b>	<b>Lumen/Watt Medium Power</b>	<b>Lumen/Watt High Power</b>	<b>LED</b>	<b>Lumen/Watt Medium Power</b>	<b>Lumen/Watt High Power</b>	<b>LED</b>	<b>Lumen/Watt Medium Power</b>	<b>Lumen/Watt High Power</b>	<b>LED</b>	<b>Lumen/Watt Medium Power</b>	<b>Lumen/Watt High Power</b>
4000K	2010lm/13W	2930lm/20W	4000K	2050lm/13W	2930lm/20W	4000K	2030lm/13W +OVAL 1920lm/13W	2920lm/20W 2770lm/20W	4000K	2000lm/13W +OVAL 1880lm/13W	2910lm/20W 2700lm/20W

Lumen Values: Luminaire luminous flux at 4000K/CRI>80. Other configurations on request.

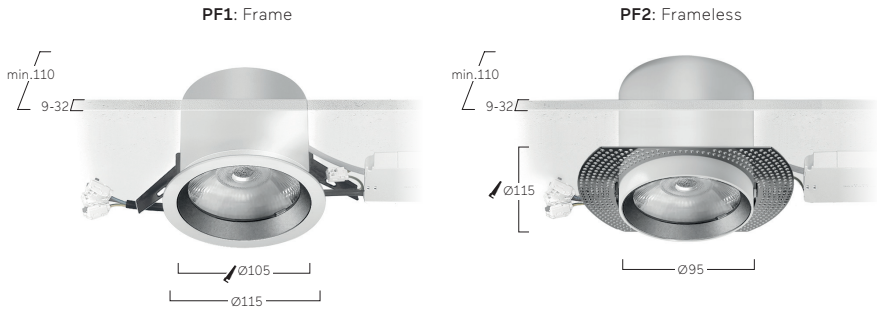

## Midpoint Déco M1 | Recessed

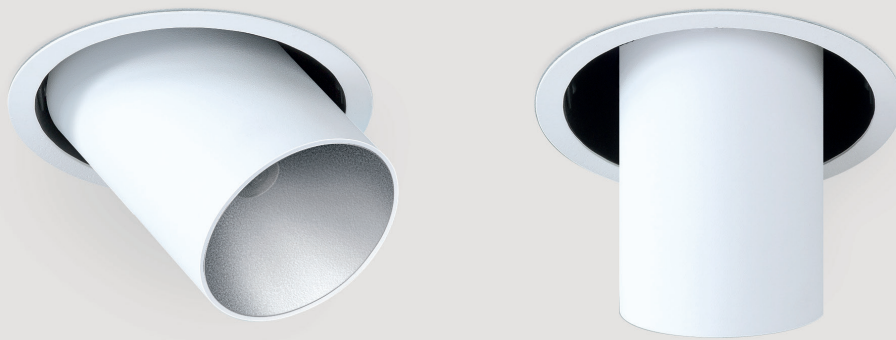

**DE** LED-Strahler für Einbaumontage in gesägten Deckenöffnungen. 350° drehbar und 90° schwenkbar. Separater Konverter im Lieferumfang enthalten, wahlweise einfach schaltbar oder stufenlos dimmbar (DALI, TRIAC, Casambi). Rückversetzte sphärische Linse für breitstrahlende Lichtverteilung (70°) und dekorativem konischen Reflektor. Gehäuse-Außenfläche und dekorativer Reflektor in unterschiedlichen Lackierungen und Kombinationen erhältlich, z.B. weiß, silber, graphit, schwarz, gold oder kupferfarben lackiert. Zu Oberflächenoptionen- und Kombinationen siehe Lightnet-Surface-Collection oder Bi-Colour-Auswahl. Linse optional mit Magic Colour Filter für colorierte Lichteffekte. Konverter in Leuchtengenhäuse integriert, einfach schaltbar oder stufenlos dimmbar (DALI, TRIAC, Casambi). Farbtemperatur 2700K, 3000K, 3500K, 4000K, Tunable White oder Dim to Warm. Binning initial  $\leq$  MacAdam 3. Farbwiedergabe CRI $>$ 90.

**EN** LED recessed spotlight for installation in ceiling cut-outs openings. 350° rotation and 90° tilt. Separate driver included, optionally switchable or dimmable (DALI, TRIAC, Casambi). Recessed spherical lens for wide-angle light distribution (70°) and decorative conical reflector. Outer housing and decorative reflector available in various finishes and combinations, e.g. white, silver, graphite, black, gold or copper coated. For surface options and combinations, see Lightnet-Surface-Collection or Bi-Colour selection. Lens optionally with Magic Colour Filter for coloured lighting effects. Driver integrated into luminaire housing, available as switched or dimmable (DALI, TRIAC, Casambi). Colour temperature 2700K, 3000K, 3500K, 4000K, Tunable White or Dim to Warm. Binning  $\leq$  MacAdam 3. Colour rendering CRI $>$ 90.

**PM1DBE-927M-BK**

Product Family	<b>P:</b> Midpoint
Type	<b>M1:</b> Direct Rotatable-Twistable
Beam Angle	<b>D:</b> Lens 70°
Surface Finish	<b>W:</b> Snow White, <b>B:</b> Jet Black, <b>V:</b> Ivory White, <b>D:</b> Anodic Black, <b>F:</b> Anodic Silver, <b>M:</b> Satin Cloud, <b>X:</b> Satin Bronze
Control Gear	<b>E:</b> On/Off, <b>L:</b> DALI, <b>C:</b> Casambi, <b>P:</b> Triac Dimming
Colour Rendering	<b>9:</b> CRI>90, <b>8:</b> CRI>80, <b>2:</b> CRI>97, <b>3:</b> CRI>97 (Fashion White), <b>4:</b> CRI>97 (Fashion Colour)
Colour Temperature	<b>27:</b> 2700K, <b>30:</b> 3000K, <b>35:</b> 3500K, <b>40:</b> 4000K, <b>DW:</b> Dim to warm 3000-1800K
Power	<b>M:</b> Medium Power, <b>H:</b> High Power
Colour Surface	<b>W:</b> Snow White, <b>B:</b> Jet Black, <b>D:</b> Anodic Black, <b>F:</b> Anodic Silver, <b>V:</b> Ivory White, <b>M:</b> Satin Cloud, <b>K:</b> Satin Copper, <b>G:</b> Satin Gold, <b>J:</b> Satin Pale Gold, <b>L:</b> Satin Cupria
Cover	<b>K:</b> Clear [Standard], <b>F:</b> Magic Colour Filter



**70° Deep Cone Lens**

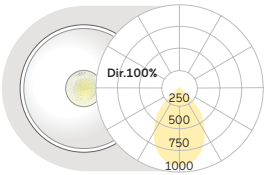

LED	Lumen/Watt Medium Power	Lumen/Watt High Power
4000K	1070lm/14W	1770lm/27W

Lumen Values: Luminaire luminous flux at 4000K/CRI>80. Other configurations on request.

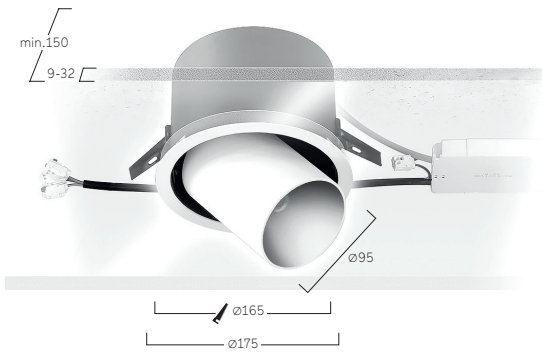

**W** Snow White  
**W** Snow White



**F** Anodic Silver  
**F** Anodic Silver



**F** Anodic Silver  
**B** Jet Black



**M** Satin Cloud  
**M** Satin Cloud



**B** Jet Black  
**K** Satin Copper

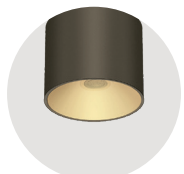

**X** Satin Bronze  
**G** Satin Gold

## Midpoint Anti-Glare M3 | Recessed

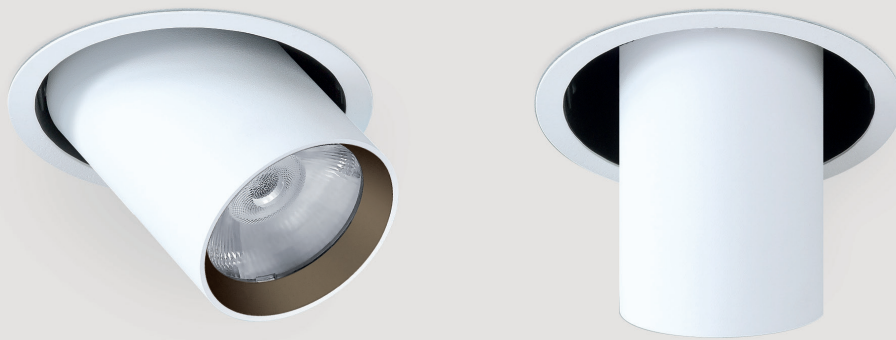

**DE** LED-Strahler für Einbaumontage in gesägten Deckenöffnungen. 350° drehbar und 90° schwenkbar. Separater Konverter im Lieferumfang enthalten, wahlweise einfach schaltbar oder stufenlos dimmbar (DALI, Casambi). Austauschbare Anti-Glare-Linse für besten Lichtkomfort. Je nach Ausführung auch mit Blendungsbegrenzung (UGR<19) für Office Anwendungen. Höchste Energieeffizienz von bis zu 155lm/W. Ausstrahlwinkel: 15° (Spot), 24° (Medium), 36° (Flood) oder 60° (Wide Flood). Optional ovale Linsen oder Wabenraster. Gehäuse-Außenfläche und dekorativer Linsenring in unterschiedlichen Lackierungen und Kombinationen erhältlich, z.B. weiß, silber, graphit, schwarz, gold oder kupferfarben lackiert. Zu Oberflächenoptionen- und Kombinationen siehe Lightnet-Surface-Collection oder Bi-Colour-Auswahl. Farbtemperatur 2700K, 3000K, 3500K, 4000K, Tunable White oder Dim to Warm. Binning initial  $\leq$  MacAdam 3. Farbwiedergabe CRI>80, CRI>90 oder CRI>97 für höchste Lichtqualität. Wahlweise auch Spezialausführungen für White & Colour-Fashion. Zuleitungskabel wahlweise transparent, rot oder schwarz.

**EN** LED recessed spotlight for installation in ceiling cut-outs openings. 350° rotation and 90° tilt. Separate driver included, with option of switched or dimmable (DALI, Casambi). Replaceable anti-glare lens for optimum lighting comfort. Depending on the version, also available with glare reduction (UGR<19) for workplaces. Highest energy efficiency of up to 155lm/W. Beam angle: 15° (Spot), 24° (Medium), 36° (Flood) or 60° (Wide Flood). Optional oval lenses or honeycomb louvre. Outer housing and decorative lens ring available in various finishes and combinations, e.g. white, silver, graphite, black, gold or copper coated. For surface options and combinations, see Lightnet-Surface-Collection or Bi-Colour selection. Colour temperature 2700K, 3000K, 3500K, 4000K, Tunable White or Dim to Warm. Binning  $\leq$  MacAdam 3. Colour rendering CRI>80, CRI>90 or CRI>97 for maximum light quality. Special versions for white & colour fashion are also available. Optional transparent, red or black Power supply cable.

**PM3DBE-927M-BK**

Product Family	<b>P:</b> Midpoint
Type	<b>M3:</b> Direct Rotatable-Twistable
Beam Angle	<b>A:</b> Anti-Glare Lens 15°, <b>B:</b> Anti-Glare Lens 24°, <b>C:</b> Anti-Glare Lens 36°, <b>F:</b> Anti-Glare Lens 60°, <b>X:</b> Anti-Glare Lens 36°+OVAL <b>Y:</b> Anti-Glare Lens 60°+OVAL
Surface Finish	<b>W:</b> Snow White, <b>B:</b> Jet Black, <b>V:</b> Ivory White, <b>D:</b> Anodic Black, <b>F:</b> Anodic Silver, <b>M:</b> Satin Cloud, <b>X:</b> Satin Bronze
Control Gear	<b>E:</b> On/Off, <b>L:</b> DALI, <b>C:</b> Casambi, <b>P:</b> Triac Dimming
Colour Rendering	<b>9:</b> CRI>90, <b>8:</b> CRI>80, <b>2:</b> CRI>97, <b>3:</b> CRI>97 (Fashion White), <b>4:</b> CRI>97 (Fashion Colour)
Colour Temperature	<b>27:</b> 2700K, <b>30:</b> 3000K, <b>35:</b> 3500K, <b>40:</b> 4000K, <b>DW:</b> Dim to warm 3000-1800K
Power	<b>M:</b> Medium Power, <b>H:</b> High Power
Cone Surface	<b>W:</b> Snow White, <b>B:</b> Jet Black, <b>D:</b> Anodic Black, <b>F:</b> Anodic Silver, <b>V:</b> Ivory White, <b>M:</b> Satin Cloud, <b>K:</b> Satin Copper, <b>G:</b> Satin Gold, <b>J:</b> Satin Pale Gold, <b>L:</b> Satin Cupria
Cover	<b>K:</b> Clear [Standard], <b>H:</b> Honeycomb Louvre



15° Anti-Glare Lens			24° Anti-Glare Lens			36° Anti-Glare Lens			60° Anti-Glare Lens		
<b>LED</b>	<b>Lumen/Watt</b>	<b>Lumen/Watt</b>	<b>LED</b>	<b>Lumen/Watt</b>	<b>Lumen/Watt</b>	<b>LED</b>	<b>Lumen/Watt</b>	<b>Lumen/Watt</b>	<b>LED</b>	<b>Lumen/Watt</b>	<b>Lumen/Watt</b>
	<b>Medium Power</b>	<b>High Power</b>		<b>Medium Power</b>	<b>High Power</b>		<b>Medium Power</b>	<b>High Power</b>		<b>Medium Power</b>	<b>High Power</b>
4000K	2010lm/13W	2930lm/20W	4000K	2050lm/13W	2930lm/20W	4000K	2030lm/13W	2920lm/20W	4000K	2000lm/13W	2910lm/20W
						+OVAL	1920lm/13W	2770lm/20W	+OVAL	1880lm/13W	2700lm/20W

Lumen Values: Luminarie luminous flux at 4000K/CRI>80. Other configurations on request.

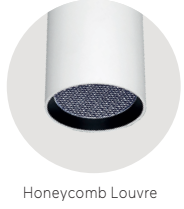
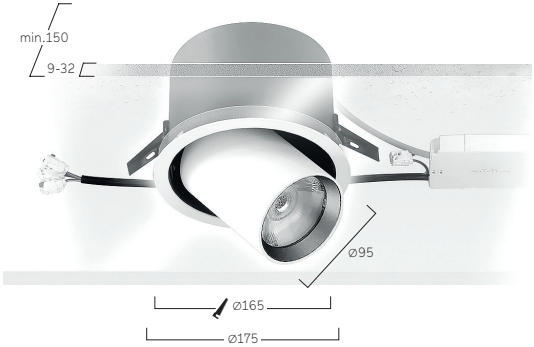



**Lightnet Headquarters Germany**

Lightnet GmbH  
Zollstockgürtel 65  
50969 Köln  
+49 221 22 25 26-0  
info@lightnet.de  
lightnet.de

**Lightnet Austria**

Lightnet Austria GmbH  
Döblinger Hauptstraße 42/9  
1190 Wien  
+43 1 39 50 793  
info@lightnet.at  
lightnet.at

**Lightnet UK**

Lightnet Group Limited  
Unit 210-211 Canalot Studios,  
222 Kensal Road  
London W10 5BN  
+44 20 81 46 69 81  
info@lightnet-group.co.uk  
lightnet-group.co.uk

**Lightnet France**

Lightnet SAS  
5, allée d'Helsinki  
67300 Schiltigheim  
+33 3 69 24 69 13  
info@lightnet.fr  
lightnet.fr

**Lightnet Poland**

Lightnet Sp. z o.o.  
ul. Sportowa 2  
43-356 Kobiernice  
+48 33 810 86 56  
info@lightnet.pl  
lightnet.pl

**Lightnet USA**

Lightnet USA Inc.  
2937 SW 27th Ave Ste 305  
Miami, FL 33133  
+1 800 94 09 092  
info@lightnet.us  
lightnet.us

**Lightnet Mexico**

Lightnet Mexico S.C.  
Francisco Ortega No 30-32  
Col. Villa Coyoacan  
CP 04000, Mexico DF  
+52 55 49 16 92 45  
info@lightnet.mx  
lightnet.mx

lightnet.de